

HYDRA BC

INSTALLATION MANUAL

EN

HANDBUCH

DE

MANUAL DE INSTALACION

ES

MANUEL D'INSTALLATION

FR

MANUALE D'INSTALLAZIONE

IT

MANUAL DE INSTALAÇÃO

PT

KULLANIM KLAVUZU

TR

РУКОВОДСТВО ПО УСТАНОВКЕ И ЭКСПЛУАТАЦИИ

RU

INSTALLATION AND START-UP MANUAL FOR HYDRA BC DOSING PUMP

Packing contents:

- A. Opaque hose for connecting the pump's outlet to the injection point
- B. Transparent hose for suction and for connecting the bleeding valve up for manual priming
- C. Injection fitting
- D. Hose connection kit
- E. Bottom filter
- F. Wall mounting bracket
- G. Anchors for securing the pump to the wall
- H. Screw protection caps
- I. Instructions Manual

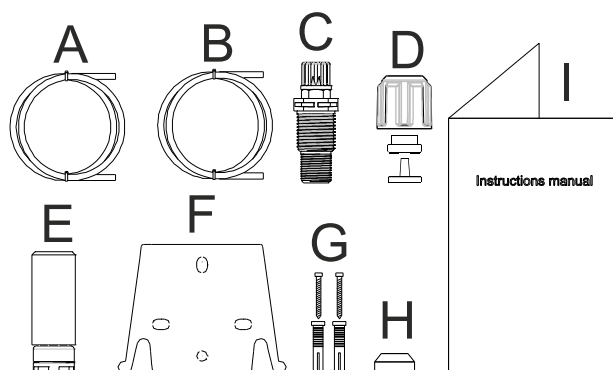

Below are the technical and pump performance data:

PVDF-T					
Model	Pressure	Flow rate	cc /stroke	Connections	stroke / min
	bar	l/h		(mm)	
5	8	5	0.52	Int / Ext	160
	10	3		4 / 6	

INTRODUCTION

The pump is composed of a part that houses the control electronics and the magnet and a hydraulic side always in contact with the liquid to be dosed.

Check the rating plate of the main features of your pump

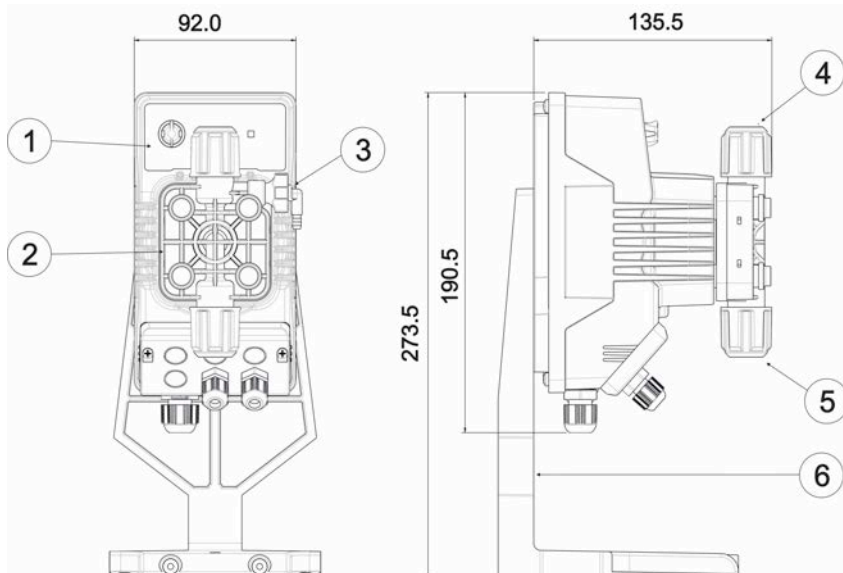

- 1. Adjustments area
- 2. Dosing head
- 3. Priming valve
- 4. Delivery connector
- 5. Suction connector
- 6. Base fixing bracket (optional)

We recommend checking the chemical compatibility between the product and the materials in contact.

PUMP HEAD MATERIALS

- **Pump body:** PVDF-T
- **Valves:** PVDF-T
- **Balls:** Ceramic
- **Diaphragm:** PTFE

SPECIFICATIONS

- **Weight:** 1.5 Kg
- **Power Supply:** 100 - 240 Vac (50-60 Hz)
- **Consumption:** 13W @ 100 Vac – 19W @ 240 Vac
- **Fuse:** 2A 250V T 5x20
- **Protection rating:** IP65
- **Level control input:** Dry contact (on-off)
- **Pulse input:** Dry contact (on-off) maximum frequency 80Hz

READ THE FOLLOWING WARNINGS BEFORE INSTALLING OR PERFORMING MAINTENANCE ON THE PUMP.



WARNING: BEFORE DOING ANY WORK ON THE PUMP, ALWAYS FIRST DISCONNECT THE POWER SUPPLY CABLE.



WARNING: WE RECOMMEND INSTALLING THE PUMP IN A VERTICAL POSITION TO ENSURE PROPER OPERATION.



ATTENTION: PRODUCT INTENDED FOR PROFESSIONAL USE BY SKILLED PERSONNEL.



ATTENTION: MAINTENANCE WORK ON THE PUMP MUST BE CARRIED OUT BY AUTHORISED AND TRAINED PERSONNEL ONLY.

- **H₂SO₄ SULPHURIC ACID** All the pumps are tested with water. Before dosing chemical products that may react with water, dry all the internal parts of the plumbing thoroughly.
- Install the pump in a zone where the environment temperature does not exceed 40°C and the relative humidity is below 90%. The pump has an IP65 protection level. Avoid installing the pump directly exposed to sunlight.
- Install the pump so that any inspection and maintenance operations are easy to carry out, then secure the pump firmly in order to prevent excessive vibrations.
- Check that the power supply available in the network is compatible with that indicated on the pump label.

WIRING

	<p>Input A = Power supply 100 - 240 Vac (50-60 Hz)</p> <p>Input B = Pulses free from voltage (pulse emission meter or Hall sensor)</p> <p>Input C = Level control probe input</p>	<p>The pump must be connected to a power supply that complies with the information indicated on the label on the side of the pump. Failure to respect these limits may cause damage to the pump itself.</p> <p>The pumps have been designed to absorb small over voltages. Therefore, in order to prevent the pump from being damaged, it is always preferable to ensure that the pump does not have a power source shared with electrical appliances that generate high voltages.</p> <p>Connection with the three-phase 380V line should only be made between phase and neutral. Connections MUST NOT be made between phase and ground.</p>																		
	<table border="1"> <tr> <td>1</td> <td>Output voltage 10 Vcc</td> </tr> <tr> <td>2</td> <td>Signal</td> </tr> <tr> <td>4</td> <td>GND</td> </tr> <tr> <td>3</td> <td>Not used.</td> </tr> <tr> <td>2</td> <td>Pulses free from voltage (pulse emission meter; dry contact: on-off, maximum frequency 80Hz)</td> </tr> <tr> <td>4</td> <td>Level control probe input (Dry contact: on-off)</td> </tr> <tr> <td>5</td> <td>Level control probe input (Dry contact: on-off)</td> </tr> <tr> <td>6</td> <td>Level control probe input (Dry contact: on-off)</td> </tr> <tr> <td>F</td> <td>Fuse: 2A 250V T 5x20.</td> </tr> </table>	1	Output voltage 10 Vcc	2	Signal	4	GND	3	Not used.	2	Pulses free from voltage (pulse emission meter; dry contact: on-off, maximum frequency 80Hz)	4	Level control probe input (Dry contact: on-off)	5	Level control probe input (Dry contact: on-off)	6	Level control probe input (Dry contact: on-off)	F	Fuse: 2A 250V T 5x20.	<p>Hall sensor or similar input (output voltage 10 Vcc; maximum current 5 mA)</p>
1	Output voltage 10 Vcc																			
2	Signal																			
4	GND																			
3	Not used.																			
2	Pulses free from voltage (pulse emission meter; dry contact: on-off, maximum frequency 80Hz)																			
4	Level control probe input (Dry contact: on-off)																			
5	Level control probe input (Dry contact: on-off)																			
6	Level control probe input (Dry contact: on-off)																			
F	Fuse: 2A 250V T 5x20.																			

DOSING MODE SETTINGS

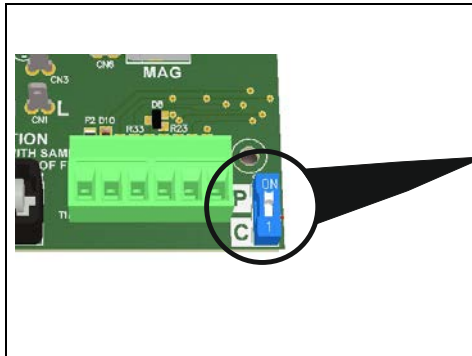

A switch (shown in the figure) that regulates the dosing mode of the pump is present in the part relative to the electrical connections on the circuit.

The two different modes are:

Constant (switch in position C)

The pump constantly dispenses the percentage selected with a potentiometer.

Proportional (switch in position P)

The pump doses proportionally to the input signal (Pulse emission meter).

PLUMBING CONNECTIONS

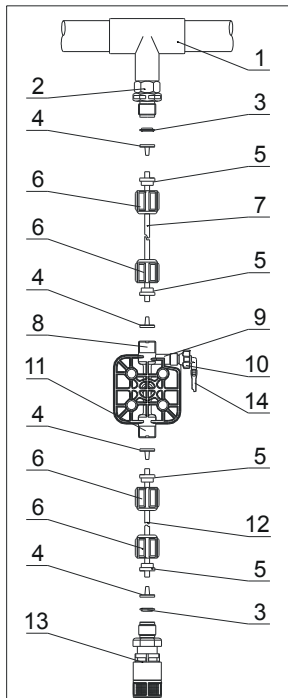

1. Injection point
2. Injection fitting
3. Seal
4. Pipe holder
5. Pipe clamp
6. Ring nut
7. Delivery hose (rigid)
8. Delivery valve
9. Pump body
10. Bleed valve
11. Suction valve
12. Suction hose (soft)
13. Bottom filter
14. Bleed valve connector

Fixing templates wall bracket

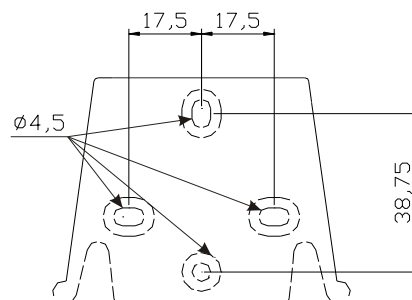

After around 800 hours of work, tighten the bolts on the pump body, applying a tightening torque of 3 Nm.

When making the plumbing connections, make sure that you follow the instructions below:

- The **BOTTOM FILTER** must be installed so that it is always positioned 5-10 cm from the bottom, in order to prevent any formation of deposits.
- Installation of the pump suction head is recommended for pumps with very low flow rates. In particular, when dosing products which develop gas (e.g. sodium hypochlorite, hydrazine, hydrogen peroxide, etc.).
- If you need to use longer hoses than those provided in the installation kit, it is important that you use hoses of the same dimensions as those supplied with the pump. If the **DELIVERY HOSE** may be exposed to the sun's rays, we recommend using a black hose able to withstand ultraviolet rays
- It is advisable to position the **INJECTION POINT** higher than the pump or tank.
- The **INJECTION VALVE**, supplied with the pump, must always be installed at the end of the delivery line on of the dosing flow.

START-UP

Once all the aforementioned operations have been completed, the pump is ready to be started.

Priming

- Start the pump.
- Open the priming connector by turning the knob in a counter-clockwise direction and wait for liquid to come out of the pipe connected to it.
- Once you are sure that the pump is completely full of liquid, you can close the connector and the pump will begin to dose.

TROUBLESHOOTING

Problem	Possible Cause	Solution
The pump is working properly but the dosage is interrupted	Blocked valve	Clean the valves or replace them if it is not possible to remove the build-ups
	Excessive suction height	Position the pump or tank so as to reduce the suction height
	Excessive liquid viscosity	Reduce the suction height or use a pump with a bigger flow capacity
Insufficient flow capacity	Leakage from the valve	Check that the ring nuts are properly tightened
	Excessive liquid viscosity	Use a pump with a bigger flow capacity or reduce the suction height
	Valve partially blocked	Clean the valves or replace them if it is not possible to remove the build-ups
Irregular pump flow capacity	Transparent PVC hose on delivery	Use an opaque PE pipe on delivery
Broken diaphragm	Excessive back-pressure	Check the system pressure. Check whether the injection valve is blocked. Check whether there are any blockages between the delivery valves and the injection point.
	Operation without liquid	Check the presence of the foot filter (valve). Use a level probe that blocks the pump when the chemical product runs out in the tank
	Membrane not secured correctly	If the membrane has been replaced, make sure that the same is correctly tightened.
The pump does not switch on	Insufficient power supply	Check whether the pump plate data corresponds to that of the electricity network.

HYDRA BC – Control Panel

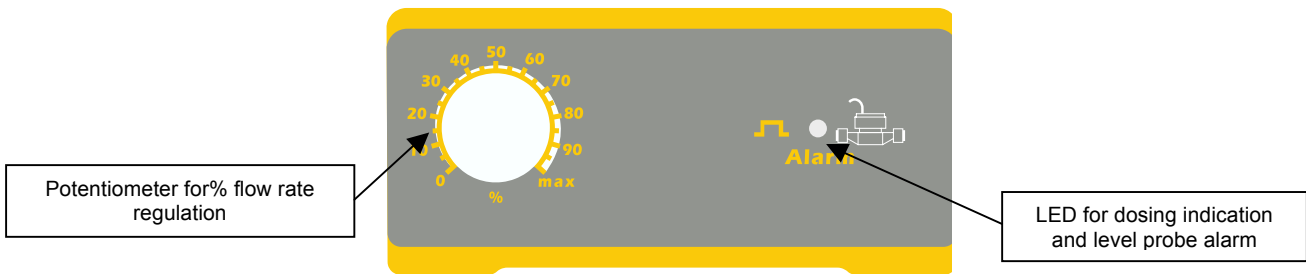

CONSTANT MODE (switch in position C)

The pump dispenses the percentage selected manually with a potentiometer. Steady green LED switches off with every stroke that the pump runs. Flashing Green led with the potentiometer to 0.

PROPORTIONAL MODE 4:1 (switch in position P)

After four received external pulses (pulse emission meter) and with the potentiometer at 100% of its regulation, it runs a stroke.

The potentiometer permits an increase in the number of received external pulses, after which the pump runs a stroke.

Below are some examples of operation:

Potentiometer [%]	1 stroke / Pulses
100	4
50	8
10	40

Steady orange LED switches off with every stroke that the pump runs. Flashing orange LED with the potentiometer at 0.

calibration meter Q_n		max pul/min available from meter $[Q_n \times \text{pul/l}]$				max pump frequency [4 pulse meter = 1 pulse pump]				max ppm available to max frequency			
size	m^3/h	pul/l		l/pul		pul/l		l/pul		pul/l		l/pul	
		4	1	100	1000	4	1	100	1000	4	1	100	1000
1/2"	1.5	100	25			25	6			521	130		
3/4"	2.5	167	42			42	10			521	130		
1"	3.5	233	58			58	15			521	130		
1"1/4	5	333	83			83	21			521	130		
1"1/2	10	667	167			160	42			500	130		
2"	15	1,000	250	2.5		160	63	0.63		333	130	1.3	
2"1/2	25				4.2			1.04				1.3	
3"	40				6.7			1.67				1.3	
4"	60				10.0			2.50				1.3	
6"	150				2.5			0.63					0.13

ALARMS

Display	Cause	Interruption
Steady red LED switches on.	End level alarm.	Restore liquid level.

INSTALLATIONS- UND INBETRIEBNAHMEANLEITUNG FÜR DIE DOSIERPUMPE SERIE HYDRA BC

Packungsinhalt:

- A. Undurchsichtiger Schlauch für den Anschluss des Pumpenausgangs an den Einspritzpunkt
- B. Transparenter Schlauch für die Ansaugung, für den Anschluss des Auslassventils und für die manuelle Befüllung
- C. Anschluss Einspitzung
- D. Satz Schlauchanschlüsse
- E. Bodenfilter
- F. Bügel für Wandmontage
- G. Dübel für die Montage des Wandbügels
- H. Schraubenschutzkappen
- I. Anleitung

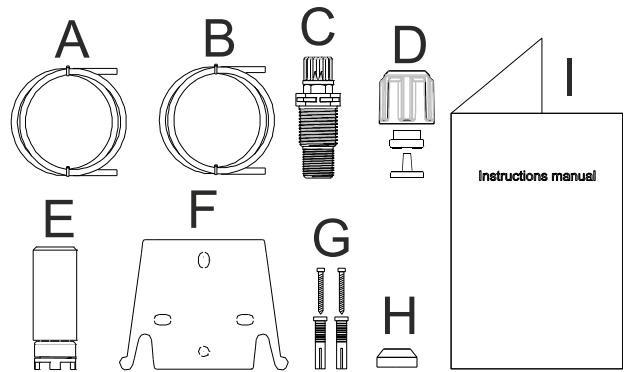

Im Folgenden werden die technischen Daten und Leistungen der Pumpe angegeben:

PVDF-T					
Modell	Druck	Fördermenge	cc/Schlag	Anschlüsse	Schlagzahl/ min
	bar	l/h		(mm) Int / Ext	
5	8	5	0,52	4 / 6	160
	10	3	0,31		

Einleitung

Die Dosierpumpe besteht aus einer Steuereinheit, in der die Elektronik und der Magnet sowie ein Teil der Hydraulik untergebracht sind, immer in Kontakt mit der zu dosierenden Flüssigkeit.

Prüfen Sie anhand der Angaben auf dem Typenschild die Haupteigenschaften Ihrer Pumpe

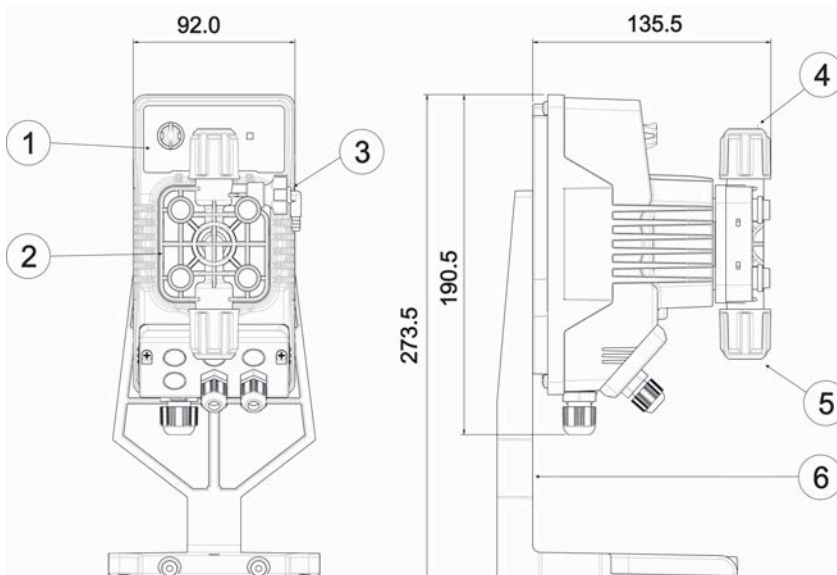

1. Einstellbereich
2. Dosierkopf
3. Befüllventil
4. Druckanschluss
5. Ansauganschluss
6. Gestell für Unterbau (optional)

Wir empfehlen eine Prüfung der chemischen Kompatibilität zwischen dem dosierten Produkt und den Kontaktmaterialien.

MATERIALIEN DES PUMPENKOPFES

- Pumpengehäuse: PVDF-T
- Ventile: PVDF-T
- Kugeln: Keramik
- Membran: PTFE

TECHNISCHE MERKMALE

- **Gewicht:** 1,5 Kg
- **Stromversorgung:** 100 ÷ 240 Vac (50-60 Hz)
- **Leistungsaufnahme:** 13W @ 100 Vac – 19W @ 240 Vac
- **Sicherung:** 2A 250V T 5x20
- **Schutzgrad:** IP65
- **Eingang Füllstandskontrolle:** Trockenkontakt (on-off)
- **Impulseingang:** Trockenkontakt (on-off) Höchsthfrequenz 80Hz

VOR DER INSTALLATION ODER WARTUNGSARBEITEN AN DER PUMPE AUFMERKSAM LESEN

 **ACHTUNG: VOR DER INSTALLATION ODER DER WARTUNG DER PUMPE IMMER ZUNÄCHST DIE VERSORGUNG TRENNEN.**

 **WIR EMPFEHLEN DIE INSTALLATION DER PUMPE IN EINER VERTIKALEN POSITION UM EINEN ORDNUNGSGEMÄSSEN BETRIEB ZU GEWÄHRLEISTEN.**

 **ACHTUNG: DAS PRODUKT IST AUSSCHLIESSLICH FÜR DEN PROFESSIONELLEN GEBRAUCH DURCH QUALIFIZIERTES PERSONAL BESTIMMT.**

 **ACHTUNG: DIE WARTUNG DER PUMPE DARF AUSSCHLIESSLICH DURCH QUALIFIZIERTES UND AUTORISIERTES PERSONAL DURCHFÜHRT WERDEN.**

- **H₂SO₄ SCHEFELSÄURE** Vor der Dosierung chemischer Produkte, die mit Wasser reagieren können, müssen alle internen Komponenten der Hydraulik getrocknet werden.
- Umgebungstemperatur unter 40°C. Relative Luftfeuchte unter 90%. Schutzgrad: IP65 Die Pumpe nicht so installieren, dass sie direkt Sonnenstrahlen ausgesetzt ist.
- Die Pumpe gut befestigen, damit übermäßige Vibrationen vermieden werden.
- Versorgungsspannung und -druck der Anlage müssen mit den Angaben auf dem Etikett der Pumpe übereinstimmen.

ELEKTRISCHE ANSCHLÜSSE

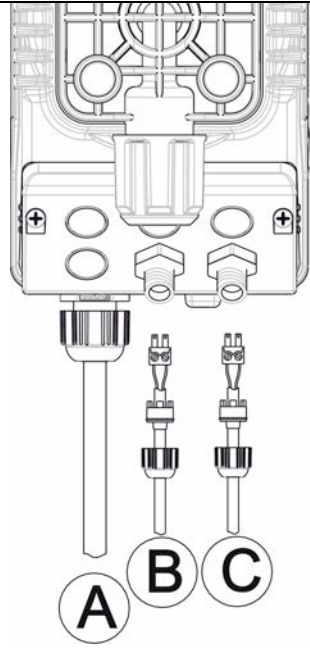
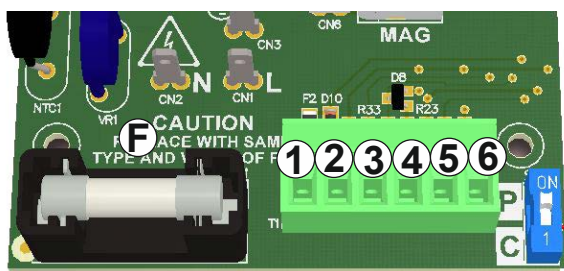
	<p>Eingang A = Versorgung 100 ÷ 240 Vac (50-60 Hz)</p> <p>Eingang B = Spannungsfreie Impulse (Impulszähler oder Hall-Sensor)</p> <p>Eingang C = Eingang Füllstandskontrollsonde</p>	<p>Die Pumpe muss an eine Versorgung angeschlossen werden, die mit den Angaben auf dem Etikett an der Seite der Pumpe übereinstimmen. Die Nichtbeachtung dieser Vorschrift kann zu Schäden an der Pumpe führen.</p> <p>Die Pumpen wurden geplant, um geringe Überspannungen absorbieren zu können. Um Schäden an der Pumpe zu vermeiden, sollte daher immer sicher gestellt werden, dass sie keine Energiequelle zusammen mit anderen elektrischen Apparaten nutzt, die hohe Spannungen erzeugen.</p> <p>Die Verbindung mit der 380V-Dreiphasenleitung darf NUR zwischen Phase und Neutralleiter vorgenommen werden. Die Anschlüsse DÜRFEN NICHT zwischen Phase und Erde erfolgen.</p>																		
	<table border="1"> <tr> <td>1</td> <td>Ausgangsspannung 10 Vcc</td> </tr> <tr> <td>2</td> <td>Signal</td> </tr> <tr> <td>4</td> <td>GND</td> </tr> <tr> <td>3</td> <td>Nicht genutzt.</td> </tr> <tr> <td>2</td> <td>Spannungsfreie Impulse (Impulszähler; Trockenkontakt: on-off, Höchsthfrequenz 80Hz)</td> </tr> <tr> <td>4</td> <td>Eingang Füllstandskontrollsonde (Trockenkontakt:on-off)</td> </tr> <tr> <td>5</td> <td>Eingang Füllstandskontrollsonde (Trockenkontakt:on-off)</td> </tr> <tr> <td>6</td> <td>Eingang Füllstandskontrollsonde (Trockenkontakt:on-off)</td> </tr> <tr> <td>F</td> <td>Sicherung: 2A 250V T 5x20.</td> </tr> </table>	1	Ausgangsspannung 10 Vcc	2	Signal	4	GND	3	Nicht genutzt.	2	Spannungsfreie Impulse (Impulszähler; Trockenkontakt: on-off, Höchsthfrequenz 80Hz)	4	Eingang Füllstandskontrollsonde (Trockenkontakt:on-off)	5	Eingang Füllstandskontrollsonde (Trockenkontakt:on-off)	6	Eingang Füllstandskontrollsonde (Trockenkontakt:on-off)	F	Sicherung: 2A 250V T 5x20.	<p>Eingang Hall-Sensor o.ä. (Ausgangsspannung 10 Vcc; Maximaler Strom 5 mA)</p>
1	Ausgangsspannung 10 Vcc																			
2	Signal																			
4	GND																			
3	Nicht genutzt.																			
2	Spannungsfreie Impulse (Impulszähler; Trockenkontakt: on-off, Höchsthfrequenz 80Hz)																			
4	Eingang Füllstandskontrollsonde (Trockenkontakt:on-off)																			
5	Eingang Füllstandskontrollsonde (Trockenkontakt:on-off)																			
6	Eingang Füllstandskontrollsonde (Trockenkontakt:on-off)																			
F	Sicherung: 2A 250V T 5x20.																			

EINSTELLUNGEN DOSIERMODALITÄTEN



Im Bereich der elektrischen Anschlüsse des Schaltkreises ist ein Schalter vorhanden (siehe Abbildung), der den Dosiermodus der Pumpe regelt.

Die zwei verschiedenen Modi sind:

Konstant (Schalter in Position C)

Die Pumpe dosiert kontinuierlich den am Potentiometer eingestellten Prozentsatz.

Proportional (Schalter in Position P)

Die Pumpe dosiert proportional beim Eingangssignal (Impulszähler).

HYDRAULIKANSCHLÜSSE

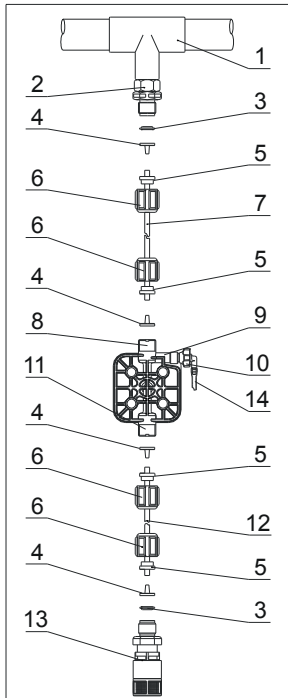

1. Einspritzpunkt
2. Anschluss Einspritzung
3. Dichtung
4. Schlauchhalterung
5. Schlauchdurchführung
6. Gewinding
7. Druckschlauch (starr)
8. Druckventil
9. Pumpengehäuse
10. Ablassventil
11. Ansaugventil
12. Ansaugschlauch (weich)
13. Bodenfilter
14. Anschluss Ablassventil

Bohrschablonen Wandbügel

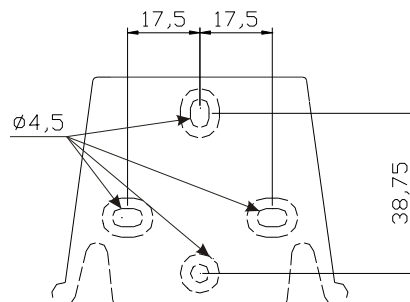

Nach etwa 800 Betriebsstunden die Bolzen des Pumpengehäuses mit einem Anzugsmoment von 3 Nm anziehen.

Zum Durchführen der Wasseranschlüsse müssen folgende Hinweise beachtet werden:

- Den **BODENFILTER** etwa 5-10cm über dem Boden installieren, um eventuelle Ablagerungen zu vermeiden
- Die Installation unter dem Flüssigkeitsstand wird bei Pumpen mit sehr geringer Fördermenge empfohlen. Insbesondere für die Dosierung von Produkten, die Gase entwickeln (z.B. Natriumhypochlorit, Hydrazin, Wasserstoffperoxid,...).
- Bei Schläuchen, die länger als die im Installationssatz enthaltenen sind, ist es wichtig, dass diese dieselben Maße wie die mit der Pumpe gelieferten aufweisen. Wenn die **DRUCKLEITUNG** Sonnenstrahlung ausgesetzt ist, empfiehlt sich der Einsatz eines schwarzen, UV-beständigen Schlauchs;
- Der **EINSPRITZPUNKT** sollte höher als die Pumpe oder der Tank liegen;
- Das **EINSPRITZVENTIL**, das mit der Pumpe geliefert wird, muss immer am Ende der Druckleitung des Dosierungsflusses installiert werden.

START

Nach der Durchführung aller zuvor beschriebenen Schritte ist die Pumpe für den Start bereit.

Befüllen

- Die Pumpe starten
- Den Befüllanschluss durch Drehen des Knaufs entgegen dem Uhrzeigersinn öffnen und warten, bis die Flüssigkeit aus der angeschlossenen Leitung tritt.
- Nachdem sicher gestellt wurde, dass die Pumpe ganz gefüllt ist, kann der Anschluss wieder geschlossen werden und die Pumpe beginnt mit der Dosierung.

PROBLEMBEHEBUNG

Störung	Mögliche Ursache	Lösung
Die Pumpe funktioniert normal, aber die Dosierung wurde unterbrochen.	Verstopfung der Ventile	Die Ventile reinigen oder, wenn es nicht möglich ist, die Verkrustungen zu entfernen, ersetzen
	Übermäßige Ansaughöhe	Die Pumpe oder den Tank so positionieren, dass die Ansaughöhe reduziert wird
	Flüssigkeit zu viskos	Die Ansaughöhe reduzieren oder eine Pumpe mit höherer Fördermenge nutzen
Unzureichende Fördermenge	Leckage der Ventile	Kontrollieren, ob die Gewinderinge korrekt angezogen sind
	Flüssigkeit zu viskos	Eine Pumpe mit höherer Fördermenge nutzen oder die Ansaughöhe reduzieren
	Teilweise Verstopfung der Ventile	Die Ventile reinigen oder, wenn es nicht möglich ist, die Verkrustungen zu entfernen, ersetzen
Unregelmäßige Fördermenge der Pumpe	Für die Druckleitung wird ein transparenter PVC-Schlauch genutzt	Einen undurchsichtigen PE-Schlauch für die Druckleitung nutzen
Membran ist kaputt	Zu hoher Gegendruck	Den Druck der Anlage prüfen. Prüfen, ob das Einspritzventil verstopft ist. Prüfen, ob zwischen den Druckventilen und dem Einspritzpunkt Verstopfungen vorhanden sind.
	Betrieb ohne Flüssigkeit	Prüfen, ob der Bodenfilter (das Ventil) vorhanden ist. Eine Füllstandssonde verwendet, die die Pumpe blockiert, wenn das chemische Produkt im Tank zu Ende geht
	Membran nicht richtig befestigt	Bei Ersatz der Membran prüfen, dass diese wieder richtig befestigt wird.
Die Pumpe geht nicht an	Unzureichende Versorgung	Prüfen, ob die Werte auf dem Typenschild der Pumpe mit denen des Stromnetzes übereinstimmen.

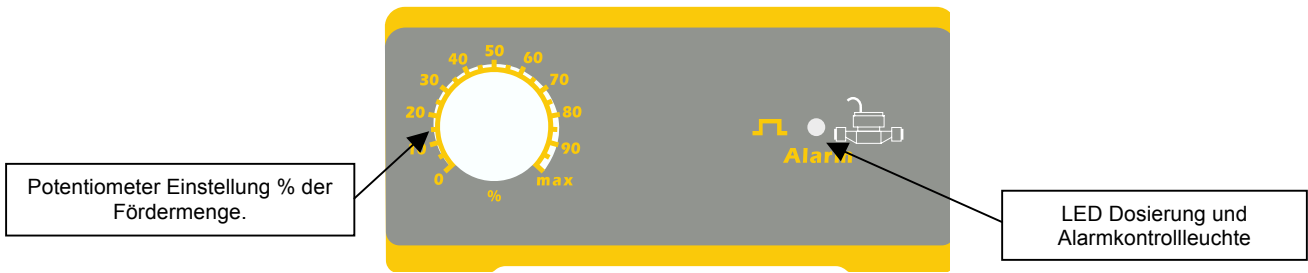

KONSTANTER MODUS (Schalter in Position C)

Die Pumpe dosiert manuell den mit dem Potentiometer gewählten Prozentsatz
 Die grüne, durchgängig leuchtende LED geht bei jedem Schlag aus, die die Pumpe durchführt.
 Die grüne LED blinkt, wenn das Potentiometer auf 0 steht.

PROPORTIONALER MODUS 4:1 (Schalter in Position P)

Die Pumpe führt einen Schlag durch, nachdem sie vier externe Schläge erhalten hat (Impulszähler) und das Potentiometer auf 100% eingestellt ist.
 Das Potentiometer gestattet die Erhöhung der Anzahl der erhaltenen externen Impulse, nach denen die Pumpe einen Schlag durchführt.
 Es folgt ein Betriebsbeispiel:

Potentiometer [%]	1 Schlag / Impulse
100	4
50	8
10	40

Die orange, durchgängig leuchtende LED geht bei jedem Schlag aus, den die Pumpe durchführt.
 Die orange LED blinkt, wenn das Potentiometer auf 0 steht.

Lehre Zähler Q_n		max vom Zähler lieferbare Imp/min [$Q_n \times \text{Imp/l}$]				max. Frequenz der Pumpe [4 Imp Zähler = 1 Imp Pumpe]				max. dosierbare ppm bei der max. Frequenz			
Größe	m^3/h	Imp/l		l/Imp		Imp/l		l/Imp		Imp/l		l/Imp	
		4	1	100	1000	4	1	100	1000	4	1	100	1000
1/2"	1,5	100	25			25	6			521	130		
3/4"	2,5	167	42			42	10			521	130		
1"	3,5	233	58			58	15			521	130		
1"1/4	5	333	83			83	21			521	130		
1"1/2	10	667	167			160	42			500	130		
2"	15	1.000	250	2,5		160	63	0,63		333	130	1,3	
2"1/2	25			4,2				1,04				1,3	
3"	40			6,7				1,67				1,3	
4"	60			10,0				2,50				1,3	
6"	150				2,5			0,63					0,13

ALARME

Anzeige	Ursache	Unterbrechung
Die rote LED leuchtet durchgängig.	Alarm minimaler Füllstand erreicht	Flüssigkeit nachfüllen.

MANUAL DE INSTALACIÓN Y PUESTA EN FUNCIONAMIENTO PARA BOMBA DOSIFICADORA SERIE HYDRA BC

Contenido del embalaje:

- A. Manguera opaca para la conexión de la salida de la bomba hasta el punto de inyección
- B. Tubo transparente para la aspiración, la conexión de la válvula de purga y para el cebado manual.
- C. Racor de inyección
- D. Kit conexiones tubos
- E. Filtro de fondo
- F. Soporte para el montaje en pared
- G. Tacos para fijar el soporte a la pared
- H. Tapones protección tornillos
- I. Manual de instrucciones

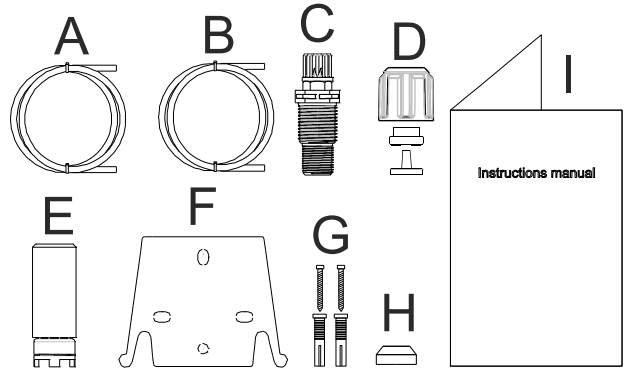

Estos son los datos técnicos y las prestaciones de la bomba:

PVDF-T					
Modelo	Presión	Caudal	cc /golpe	Conexiones (mm)	Golpes / min
	bares	l/h		Int / Ext	
5	8	5	0,52	4 / 6	160
	10	3	0,31		

INTRODUCCIÓN

La bomba dosificadora está formada por un mando con los dispositivos electrónicos y un imán, así como una parte hidráulica que siempre está en contacto con el líquido que se va a dosificar.

Controle en la placa los datos con las características principales de la bomba

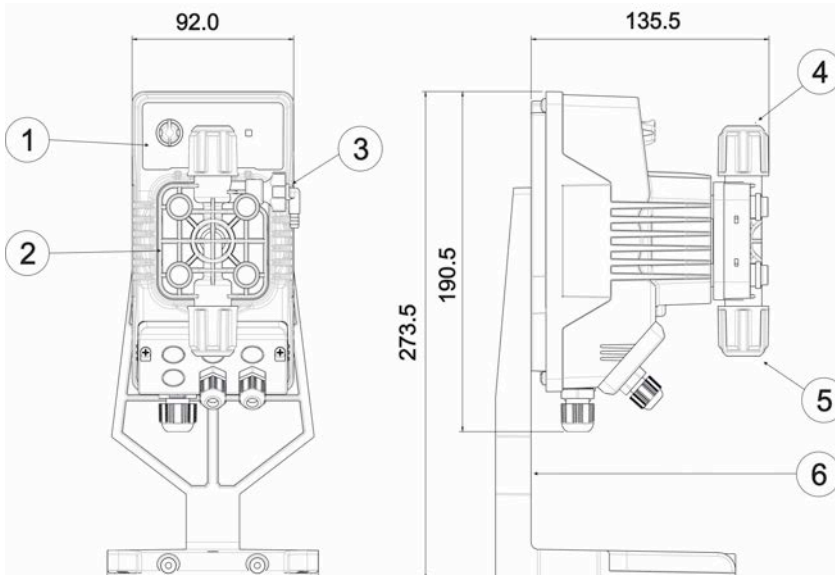

1. Área regulaciones
2. Cabezal dosificador
3. Válvula de cebado
4. Racor de impulsión
5. Racor de aspiración
6. Soporte de montaje (opcional)

Se recomienda una revisión de la compatibilidad química entre el producto dosificado y los materiales en contacto.

MATERIALES QUE FORMAN PARTE DEL CABEZAL DE LA BOMBA

- **Cuerpo bomba:** PVDF-T
- **Válvulas:** PVDF-T
- **Esferas:** Cerámica
- **Membrana:** PTFE

CARACTERÍSTICAS TÉCNICAS

- **Peso:** 1,5 Kg
- **Alimentación:** 100 ÷ 240 Vac (50-60 Hz)
- **Consumo:** 13W @ 100 Vac – 19W @ 240 Vac
- **Fusible:** 2A 250V T 5x20
- **Grado de protección:** IP65
- **Entrada control nivel:** Contacto seco (on-off)
- **Entrada impulsos:** Contacto seco (on-off) frecuencia máxima 80Hz

LEA ATENTAMENTE ANTES DE REALIZAR LA INSTALACIÓN O CUALQUIER OPERACIÓN DE MANTENIMIENTO EN LA BOMBA.



ATENCIÓN: ANTES DE REALIZAR LA INSTALACIÓN O EL MANTENIMIENTO DE LA BOMBA, DESCONECTE LA CORRIENTE ELÉCTRICA.



ATENCIÓN: RECOMENDAMOS LA INSTALACIÓN DE LA BOMBA EN POSICIÓN VERTICAL PARA GARANTIZAR EL CORRECTO FUNCIONAMIENTO.



ATENCIÓN: PRODUCTO DE USO PROFESIONAL, OPERADO SOLAMENTE POR PERSONAL CALIFICADO.



ATENCIÓN: EL MANTENIMIENTO DE LA BOMBA MUST SOLO DEBE SER EFECTUADO POR PERSONAL CALIFICADO Y AUTORIZADO.

- **H₂SO₄ ACIDO SULFURICO** Antes de dosificar los productos que puedan reaccionar con el agua, es necesario secar todas las partes internas de la hidráulica.
- Temperatura ambiente menor a 40°C. Humedad relativa menor a 90%. Grado de protección IP65 No instale la bomba donde quede expuesta directamente a los rayos solares.
- Asegure la bomba para evitar vibraciones excesivas.
- La tensión de alimentación y la presión en el sistema deben ser compatibles con lo descrito en la placa de la bomba.

CONEXIONES ELÉCTRICAS

	<p>Entrada A = Alimentación 100 ÷ 240 Vac (50-60 Hz)</p> <p>Entrada B = Impulsos de voltaje libres (contador lanza-impulsos o sensor hall)</p> <p>Entrada C = Entrada sonda de control nivel</p>	<p>La bomba debe conectarse a una línea eléctrica que sea conforme con la que figura en la etiqueta de la bomba. El incumplimiento de estas instrucciones puede causar daños a la bomba.</p> <p>Las bombas están diseñadas para absorber pequeñas sobre tensiones. Por lo tanto, para evitar daños en la bomba es conveniente asegurarse que la bomba no tenga ninguna fuente de energía compartida con los aparatos eléctricos que generan altos voltajes.</p> <p>La conexión a la línea trifásica de 380V sólo debe realizarse entre fase y neutro. La conexión NO DEBE efectuarse entre fase y tierra.</p>																		
	<table border="1"> <tr> <td>1</td> <td>Tensión de salida 10 Vcc</td> </tr> <tr> <td>2</td> <td>Señal</td> </tr> <tr> <td>4</td> <td>GND</td> </tr> <tr> <td>3</td> <td>No usado.</td> </tr> <tr> <td>2</td> <td>Impulsos de voltaje libres (contador lanza-impulsos; contacto seco: on-off, frecuencia máxima 80Hz)</td> </tr> <tr> <td>4</td> <td>Entrada sonda de control del nivel (Contacto seco: on-off)</td> </tr> <tr> <td>5</td> <td>Entrada sonda de control del nivel (Contacto seco: on-off)</td> </tr> <tr> <td>6</td> <td>Entrada sonda de control del nivel (Contacto seco: on-off)</td> </tr> <tr> <td>F</td> <td>Fusible: 2A 250V T 5x20.</td> </tr> </table>	1	Tensión de salida 10 Vcc	2	Señal	4	GND	3	No usado.	2	Impulsos de voltaje libres (contador lanza-impulsos; contacto seco: on-off, frecuencia máxima 80Hz)	4	Entrada sonda de control del nivel (Contacto seco: on-off)	5	Entrada sonda de control del nivel (Contacto seco: on-off)	6	Entrada sonda de control del nivel (Contacto seco: on-off)	F	Fusible: 2A 250V T 5x20.	<p>Entrada sensor hall o similar (tensión de salida 10 Vcc; corriente máxima 5 mA)</p>
1	Tensión de salida 10 Vcc																			
2	Señal																			
4	GND																			
3	No usado.																			
2	Impulsos de voltaje libres (contador lanza-impulsos; contacto seco: on-off, frecuencia máxima 80Hz)																			
4	Entrada sonda de control del nivel (Contacto seco: on-off)																			
5	Entrada sonda de control del nivel (Contacto seco: on-off)																			
6	Entrada sonda de control del nivel (Contacto seco: on-off)																			
F	Fusible: 2A 250V T 5x20.																			

PROGRAMACIONES MODO DE DOSIFICACIÓN

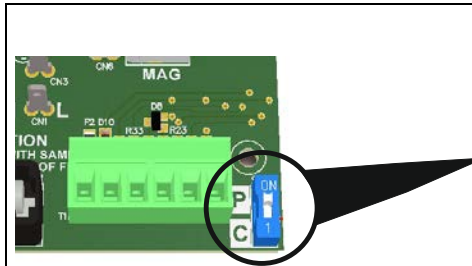

En las conexiones eléctricas del circuito, hay un interruptor (que se muestra en la figura), que regula la bomba dosificadora.

Los modos son:

Constante (switch en posición C)

La bomba dosifica en forma permanente de acuerdo con el porcentaje seleccionado con el potenciómetro.

Proporcional (switch en posición P)

La bomba dosifica en forma proporcional a la señal de entrada (Contador lanza-impulsos).

CONEXIONES HIDRÁULICAS

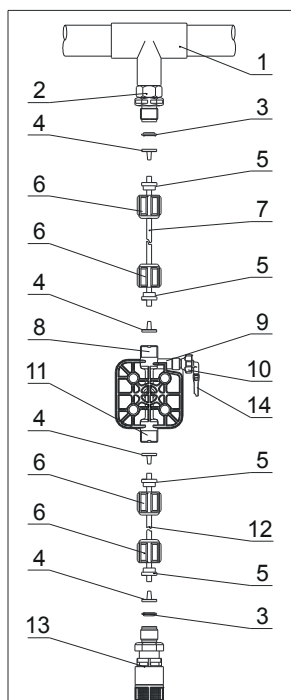

1. Punto de inyección
2. Racor de inyección
3. Estanqueidad
4. Porta-tubo
5. Prensa tubo
6. Abrazadera
7. Tubo impulsión (rígido)
8. Válvula de impulsión
9. Cuerpo bomba
10. Válvula de purga
11. Válvula de aspiración
12. Tubo de aspiración (blando)
13. Filtro de fondo
14. Racor válvula de purga

Dime de perforación del soporte de pared

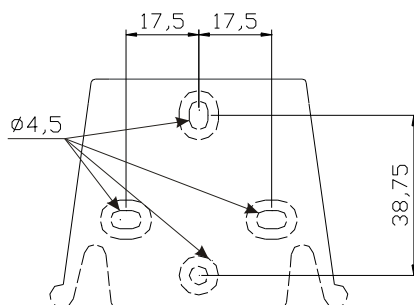

Transcurridas unas 800 horas de trabajo, apretar los tornillos del cuerpo bomba aplicando un par de apriete de 3 Nm.

Al hacer las conexiones hidráulicas debe seguir las siguientes instrucciones:

- Instalar el **FILTRO DE FONDO** a unos 5-10cm del fondo para evitar que se obstruya por los depósitos;
- LA instalación con bomba a la altura de aspiración se recomienda en bombas con caudal bajo. En particular, cuando se dosifican productos que crean gases (por ejemplo, hipoclorito de sodio, la hidracina, el peróxido de hidrógeno, ...).
- Los tubos de longitud superior a los del Kit de instalación es importante que sean del mismo tamaño que los suministrados con la bomba. Si el **TUBO DE IMPULSIÓN** se expone a los rayos solares se recomienda utilizar tubo negro resistente a los rayos ultravioleta;
- El **PUNTO DE INYECCIÓN** debe colocarse más alto que la bomba o el tanque;
- La **VÁLVULA DE INYECCIÓN** que se suministra con la bomba, se debe instalar siempre en el extremo de la línea de impulsión del flujo de dosificación.

PUESTA EN MARCHA

Una vez que haya comprobado todos los pasos anteriores, la bomba ya está lista para arrancar.

Cebado

- Poner en marcha la bomba
- Abra el racor de cebado girando la perilla en sentido antihorario y esperar que el líquido salga desde el tubo conectado a él.
- Una vez que esté seguro de que la bomba está completamente llena de líquido puede cerrar la conexión y la bomba comienza a dosificar.

SOLUCIÓN DE PROBLEMAS

Avería	Causa posible	Solución
La bomba está funcionando con normalidad, pero la dosificación se interrumpe.	Obstrucción de la válvulas	Limpie o reemplace las válvulas si no se puede remover el sucio
	Altura de aspiración excesiva	Coloque la bomba o el tanque con el fin de reducir la altura de aspiración
	Líquido muy viscoso	Reducir la altura de aspiración o utilizar bomba con mayor caudal
Caudal insuficiente	Fugas en las válvulas	Compruebe el apriete de las abrazaderas
	Líquido muy viscoso	Utilice bomba con mayor caudal o disminuya la altura de aspiración
	Obstrucción parcial de la válvulas	Limpie o reemplace las válvulas si no se puede remover el sucio
Caudal de la bomba irregular	Tubo PVC transparente en la impulsión	Utilice tubo PE opaca en la impulsión
Rotura de la membrana	Contrapresión excesiva	Controlar la presión del sistema Comprobar que la válvula de inyección no esté obstruida. Comprobar que no exista obstrucción entre las válvulas de impulsión y el punto de inyección.
	Funcionamiento sin líquido	Comprobar la presencia del filtro (válvula) de fondo. Utilice una sonda de nivel para bloquear la bomba cuando en el tanque se acaba el producto químico.
	La membrana no está fijada correctamente	Si la membrana ha sido reemplazada comprobar que se haya ajustado correctamente.
La bomba no se enciende	Corriente eléctrica insuficiente	Comprobar que los valores que figuran en la placa de la bomba correspondan con los de la red eléctrica.

Panel de control – HYDRA BC

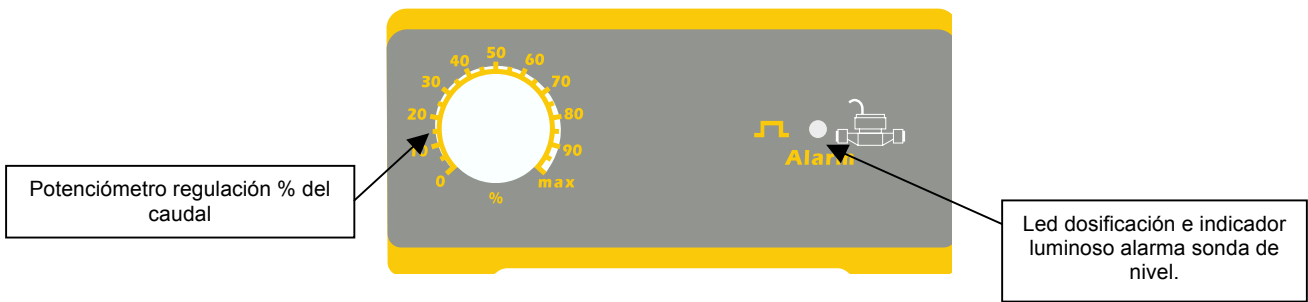

MODO CONSTANTE (switch en posición C)

La bomba dosifica el porcentaje seleccionado de forma manual con el potenciómetro. El led verde fijo se apaga con cada golpe que la bomba efectúa. Led verde parpadeante con el potenciómetro en 0.

MODO PROPORCIONAL 4:1 (switch en posición P)

Con el potenciómetro al 100% y después de recibir cuatro impulsos (contador lanza impulsos), la bomba efectúa un golpe. El potenciómetro está diseñado para aumentar el número de impulsos externos recibidos, después de los cuales la bomba realiza un golpe. Estos son algunos ejemplos de funcionamiento:

Potenciómetro [%]	1 golpe / Impulsos
100	4
50	8
10	40

El led naranja fijo se apaga con cada golpe que la bomba efectúa. Led naranja parpadeante con el potenciómetro en 0.

calibre contador Q_n		máx imp/min del contador $[Q_n \times \text{imp/l}]$				frecuencia máx de la bomba $[4 \text{ imp contador} = 1 \text{ imp bomba}]$				máx ppm dosificables con la frecuencia máx			
tamaño	m^3/h	imp/l		l/imp		imp/l		l/imp		imp/l		l/imp	
		4	1	100	1000	4	1	100	1000	4	1	100	1000
1/2"	1,5	100	25			25	6			521	130		
3/4"	2,5	167	42			42	10			521	130		
1"	3,5	233	58			58	15			521	130		
1"1/4	5	333	83			83	21			521	130		
1"1/2	10	667	167			160	42			500	130		
2"	15	1.000	250	2,5		160	63	0,63		333	130	1,3	
2"1/2	25			4,2				1,04				1,3	
3"	40			6,7				1,67				1,3	
4"	60			10,0				2,50				1,3	
6"	150				2,5				0,63				0,13

ALARMAS

Visualización	Causa	Interrupción
Encendido led de color rojo fijo.	Alarma terminación nivel	Restablecer el nivel del líquido.

MANUEL INSTALLATION ET MISE EN SERVICE POUR POMPE DOSEUSE SÉRIE HYDRA BC

Contenu de l'emballage :

- A. Tube opaque pour le raccordement de la sortie de la pompe au point d'injection
- B. Tube transparent pour l'aspiration, pour le raccordement de la valve de purge et pour l'amorçage manuel
- C. Raccord d'injection
- D. Kit raccords tubes
- E. Filtre de fond
- F. Étrier pour montage mural
- G. Chevilles pour la fixation de l'étrier au mur
- H. Bouchons protection vis
- I. Manuel d'instructions

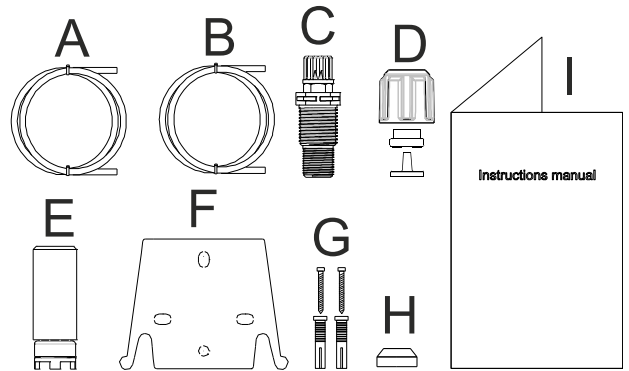

Voici les données techniques et les prestations de la pompe :

PVDF-T					
Modèle	Pression	Débit	cc / injection	Connexions	Injections / min
	bar			l/h	
5	8	5	0,52	4 / 6	160
	10	3	0,31		

INTRODUCTION

La pompe doseuse est composée d'un dispositif de commande qui loge l'électronique et l'aimant et d'une partie hydraulique toujours en contact avec le liquide à doser.

Vérifier les principales caractéristiques de votre pompe sur les données indiquées sur la plaque.

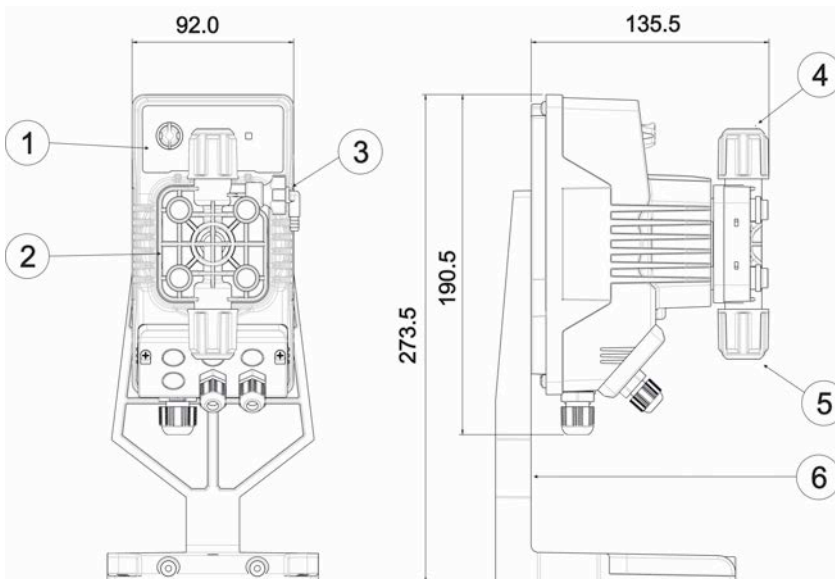

1. Zone de réglages
2. Tête doseuse
3. Clapet d'amorçage
4. Raccord de refoulement
5. Raccord d'aspiration
6. Support pour base (en option)

Nous conseillons de vérifier la compatibilité chimique entre le produit dosé et les matériaux en contact.

MATÉRIAUX QUI COMPOSENT LA TÊTE DE LA POMPE

- Boîtier pompe : PVDF-T
- Vannes : PVDF-T
- Billes de clapet : Céramique
- Membrane : PTFE

CARACTÉRISTIQUES TECHNIQUES

- **Poids :** 1,5 Kg
- **Alimentation :** 100 ÷ 240 Vac (50-60 Hz)
- **Absorption :** 13W @ 100 Vac – 19W @ 240 Vac
- **Fusible :** 2A 250V T 5x20
- **Degré de protection :** IP65
- **Entrée contrôle niveau :** Contact sec (on-off)
- **Entrée impulsions :** Contact sec (on-off) fréquence maximum 80Hz

LIRE ATTENTIVEMENT AVANT DE PROCÉDER À L'INSTALLATION OU AVANT L'ENTRETIEN DE LA POMPE.



ATTENTION : AVANT DE PROCÉDER À L'INSTALLATION OU À L'ENTRETIEN DE LA POMPE, TOUJOURS DÉBRANCHER L'ALIMENTATION.



ATTENTION: NOUS RECOMMANDONS L'INSTALLATION DE LA POMPE EN POSITION VERTICALE AFIN D'ASSURER LE BON FONCTIONNEMENT DE CETTE DERNIÈRE.



ATTENTION : PRODUIT DESTINÉ UNIQUEMENT À UN USAGE PROFESSIONNEL, À DU PERSONNEL QUALIFIÉ.



ATTENTION : L'ENTRETIEN DE LA POMPE MUST DOIT ÊTRE EFFECTUÉ UNIQUEMENT PAR DU PERSONNEL QUALIFIÉ ET AUTORISÉ.

- **H₂SO₄ ACIDE SULPHURIQUE** Avant de doser des produits chimiques qui peuvent réagir à l'eau il est nécessaire de sécher toutes les parties hydrauliques internes.
- Température ambiante inférieure à 40°C. Humidité relative inférieure à 90%. Degré de protection IP65. Éviter d'installer la pompe avec un exposition directe aux rayons solaires.
- Fixer solidement la pompe afin d'éviter des vibrations excessives.
- La tension d'alimentation et la pression sur l'installation doivent être compatibles avec les données indiquées sur l'étiquette de la pompe.

BRANCHEMENTS ELECTRIQUES

	<p>Entrée A = Alimentation 100 ÷ 240 Vac (50-60 Hz)</p> <p>Entrée B = Impulsions tension libre (compteur d'impulsions ou capteur hall)</p> <p>Entrée C = Entrée sonde contrôle niveau</p>	<p>La pompe doit être branchée à une alimentation conforme à celle indiquée sur l'étiquette sur le côté de la pompe. Le non respect de ces indications peut provoquer des dommages à la pompe.</p> <p>Les pompes ont été conçues pour absorber de petites surtensions. Afin d'éviter que la pompe ne subisse de dommages, il est conseillé de toujours s'assurer que la pompe ne partage pas de source d'énergie avec les appareils électriques qui génèrent des tensions élevées.</p> <p>La connexion avec la ligne triphasée 380V DOIT être effectuée seulement entre phase et neutre. La connexion NE DOIT pas être effectuée entre phase et terre.</p>																		
	<table border="1"> <tr> <td>1</td> <td>Tension de sortie 10 Vcc</td> </tr> <tr> <td>2</td> <td>Signal</td> </tr> <tr> <td>4</td> <td>GND</td> </tr> <tr> <td>3</td> <td>Non utilisé.</td> </tr> <tr> <td>2</td> <td>Impulsions tension libre (compteur d'impulsions ; contact sec : on-off, fréquence maximum 80Hz)</td> </tr> <tr> <td>4</td> <td>Entrée sonde contrôle niveau (Contact sec : on-off)</td> </tr> <tr> <td>5</td> <td>Entrée sonde contrôle niveau (Contact sec : on-off)</td> </tr> <tr> <td>6</td> <td>Entrée sonde contrôle niveau (Contact sec : on-off)</td> </tr> <tr> <td>F</td> <td>Fusible : 2A 250V T 5x20.</td> </tr> </table>	1	Tension de sortie 10 Vcc	2	Signal	4	GND	3	Non utilisé.	2	Impulsions tension libre (compteur d'impulsions ; contact sec : on-off, fréquence maximum 80Hz)	4	Entrée sonde contrôle niveau (Contact sec : on-off)	5	Entrée sonde contrôle niveau (Contact sec : on-off)	6	Entrée sonde contrôle niveau (Contact sec : on-off)	F	Fusible : 2A 250V T 5x20.	<p>Entrée capteur hall ou similaire (tension de sortie 10 Vcc ; courant maximum 5 mA)</p>
1	Tension de sortie 10 Vcc																			
2	Signal																			
4	GND																			
3	Non utilisé.																			
2	Impulsions tension libre (compteur d'impulsions ; contact sec : on-off, fréquence maximum 80Hz)																			
4	Entrée sonde contrôle niveau (Contact sec : on-off)																			
5	Entrée sonde contrôle niveau (Contact sec : on-off)																			
6	Entrée sonde contrôle niveau (Contact sec : on-off)																			
F	Fusible : 2A 250V T 5x20.																			

CONFIGURATIONS MODALITE DOSAGE

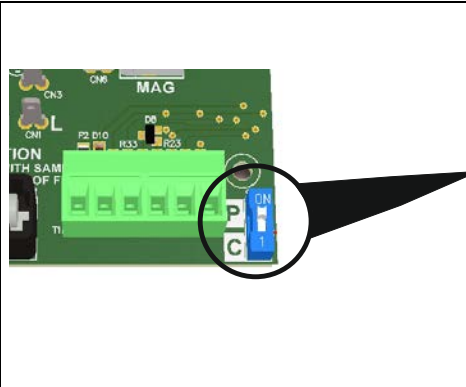

Un interrupteur (indiqué sur la figure) qui règle les modalités de dosage de la pompe est présent sur la partie correspondant aux branchements électriques du circuit.

Les deux modalités différentes sont :

Constante (interrupteur sur la position C)

La pompe dose constamment au pourcentage sélectionné avec le potentiomètre.

Proportionnelle (interrupteur sur la position P)

La pompe dose proportionnellement au signal d'entrée (Compteur d'impulsions).

BRANCHEMENTS HYDRAULIQUES

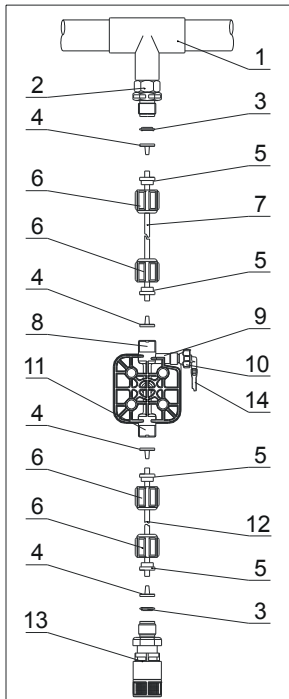

1. Point d'injection
2. Raccord d'injection
3. Étanchéité
4. Porte-tuyau
5. Presse-tube
6. Bague
7. Tube de refoulement (rigide)
8. Clapet de refoulement
9. Boîtier pompe
10. Valve de purge
11. Clapet d'aspiration
12. Tube d'aspiration (souple)
13. Filtre de fond
14. Raccord valve de purge

Gabarits perçage étrier mural

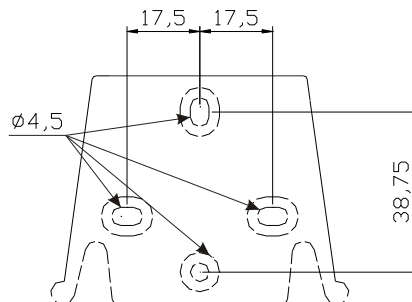

Après environ 800 heures de fonctionnement, serrer les boulons du boîtier de pompe en appliquant un couple de serrage de 3 Nm.

Suivre les instructions suivantes lors des branchements hydrauliques :

- Installer le **FILTRE DE FOND** à environ 5-10 cm du fond de façon à éviter des dépôts éventuels ;
- L'installation avec pompe sous charge d'eau est recommandée pour des pompes ayant un débit très faible. En particulier en cas de dosage de produits qui développent du gaz (par ex: hypochlorite de soude, hydrazine, peroxyde d'hydrogène...).
- Tubes plus longs que ceux du kit d'installation, il est important qu'ils aient la même dimension que ceux fournis avec la pompe. Si le **TUBE DE REFOULEMENT** est exposé aux rayons solaires on conseille l'utilisation d'un tube noir résistant aux rayons ultraviolets ;
- On conseille de placer le **POINT D'INJECTION** plus haut que la pompe ou que le réservoir ;
- Le **CLAPET D'INJECTION** fourni avec la pompe doit toujours être installé au bout de la ligne de refoulement du flux de dosage.

DEMARRAGE

Une fois que toutes les opérations décrites précédemment ont été contrôlées, la pompe peut être démarrée.

Amorçage

- Démarrer la pompe
- Ouvrir le dispositif d'amorçage en tournant la poignée dans le sens anti-horaire et attendre que le liquide sorte du tube auquel il est raccordé.
- Une fois avoir contrôlé que la pompe est parfaitement pleine de liquide, refermer le dispositif et la pompe commencera à doser.

RÉSOLUTION DES PROBLÈMES

Panne	Cause possible	Solution
La pompe fonctionne régulièrement mais le dosage s'est interrompu	Clapets obstrués	Nettoyer les clapets et les remplacer si les incrustations ne peuvent pas être retirées
	Hauteur d'aspiration excessive	Placer la pompe ou le réservoir de façon à réduire la hauteur d'aspiration
	Liquide trop visqueux	Réduire la hauteur d'aspiration ou utiliser une pompe avec des débits supérieurs
Débit insuffisant	Fuites des clapets	Contrôler le serrage des bagues
	Liquide trop visqueux	Utiliser une pompe avec des débits supérieurs ou réduire la hauteur d'aspiration
	Clapets partiellement obstrués	Nettoyer les clapets et les remplacer si les incrustations ne peuvent pas être retirées
Débit de la pompe irrégulier	Tube PVC transparent sur le refoulement	Utiliser le tube en PE opaque sur le refoulement
Membrane cassée	Contre-pression excessive	Contrôler la pression de l'installation. Vérifier si le clapet d'injection est obstrué. Vérifier si les clapets de refoulement et le point d'injection sont obstrués.
	Fonctionnement sans liquide	Vérifier la présence du filtre (clapet) de fond. Utiliser une sonde de niveau qui bloque la pompe quand le produit chimique se termine dans le réservoir
	Membrane non fixée correctement	Si la membrane a été remplacée, vérifier son serrage.
La pompe ne démarre pas	Alimentation insuffisante	Vérifier si les valeurs indiquées sur la plaque de la pompe correspondent à celles du réseau électrique.

Panneau de configuration – HYDRA BC

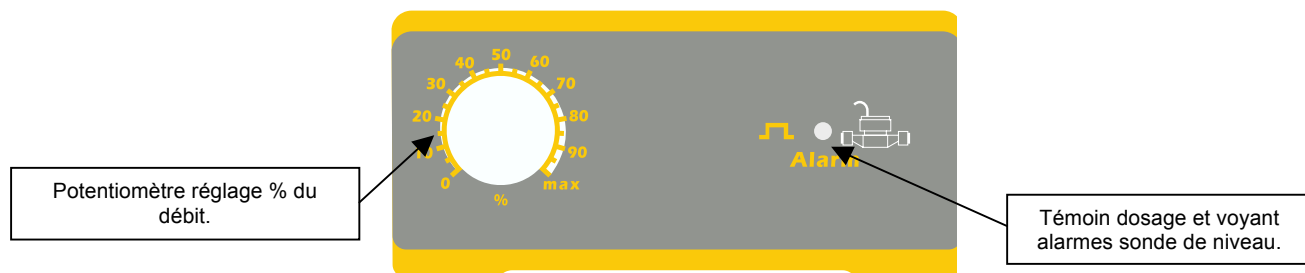

MODALITE CONSTANTE (Interrupteur sur position C)

La pompe dose manuellement le pourcentage sélectionné avec le potentiomètre.
Le témoin vert fixe s'éteint à chaque injection que la pompe effectue.
Témoin vert clignotant avec le potentiomètre à 0.

MODALITE PROPORTIONNELLE 4:1 (interrupteur sur position P)

La pompe effectue une injection après quatre impulsions externes reçues (compteur d'impulsions) et avec le potentiomètre à 100 % du réglage.
Le potentiomètre permet d'augmenter le nombre d'impulsions externes reçues, après lesquels la pompe effectuera une injection.
Des exemples de fonctionnement sont indiqués ci-dessous :

Potentiomètre [%]	1 injection / Impulsions
100	4
50	8
10	40

Le témoin orange fixe s'éteint à chaque injection que la pompe effectue.
Témoin orange clignotant avec le potentiomètre à 0.

calibre compteur Q_n		imp./min max. que peut fournir le compteur [$Q_n \times \text{imp/l}$]				fréquence max. de la pompe [4 imp. compteur = 1 imp. pompe]				ppm max. dosables à la fréquence max.			
size	m^3/h	imp/l		l/imp		imp/l		l/imp		imp/l		l/imp	
		4	1	100	1000	4	1	100	1000	4	1	100	1000
1/2"	1,5	100	25			25	6			521	130		
3/4"	2,5	167	42			42	10			521	130		
1"	3,5	233	58			58	15			521	130		
1"1/4	5	333	83			83	21			521	130		
1"1/2	10	667	167			160	42			500	130		
2"	15	1 000	250	2,5		160	63	0,63		333	130	1,3	
2"1/2	25			4,2				1,04				1,3	
3"	40			6,7				1,67				1,3	
4"	60			10,0				2,50				1,3	
6"	150				2,5				0,63				0,13

ALARMES

Affichage	Cause	Interruption
Démarrage témoin couleur rouge fixe.	Alarme fin de niveau.	Rétablir le niveau liquide.

MANUALE INSTALLAZIONE E MESSA IN SERVIZIO PER POMPA DOSATRICE SERIE HYDRA BC

Contenuto dell'imballo:

- A. Tubo opaco per il collegamento dell'uscita della pompa al punto di iniezione
- B. Tubo trasparente per l'aspirazione, per il collegamento della valvola di spurgo e per l'adescamento manuale
- C. Raccordo iniezione
- D. Kit connessioni tubi
- E. Filtro di fondo
- F. Staffa per il montaggio a parete
- G. Tasselli per il fissaggio della staffa a parete
- H. Tappi protezione viti corpo pompa
- I. Manuale d'istruzioni

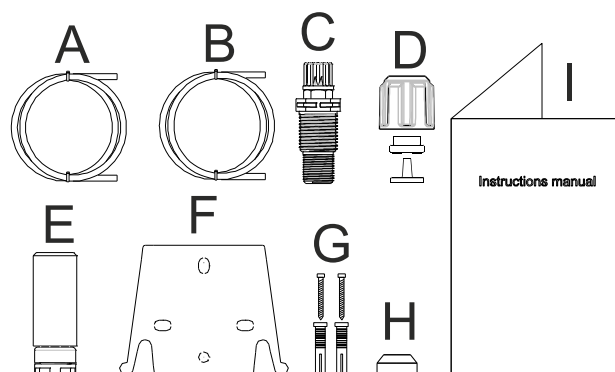

Questi sono i dati tecnici e le prestazioni della pompa:

Modello	PVDF-T			Connesioni (mm)	Colpi / min
	Pressione	Portata	cc /colpo		
	bar	l/h		Int / Ext	
5	8	5	0,52	4 / 6	160
	10	3	0,31		

INTRODUZIONE

La pompa dosatrice è composta di una parte di comando che alloggia l'elettronica ed il magnete ed una parte idraulica sempre a contatto con il liquido da dosare.

Verificate sui dati di targa le caratteristiche principali della vostra pompa

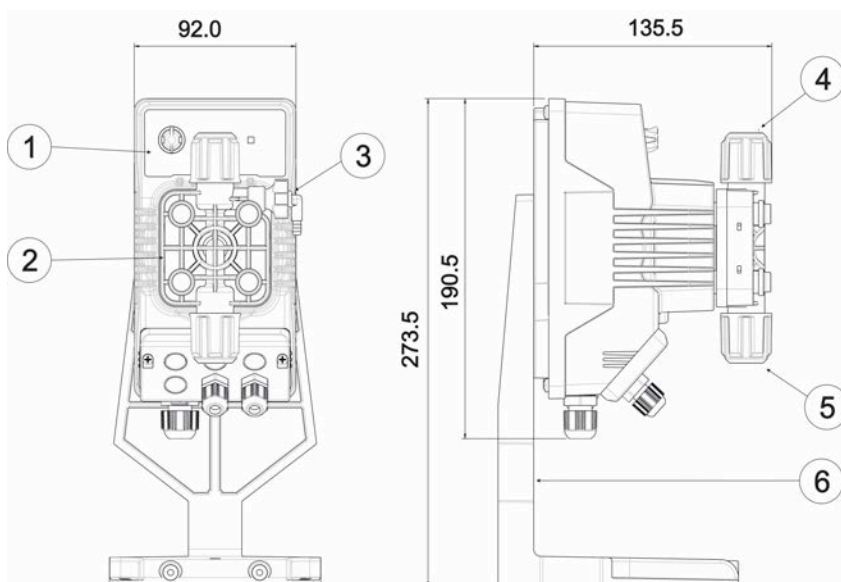

1. Area regolazioni
2. Testa dosatrice
3. Valvola per l'adescamento
4. Raccordo di mandata
5. Raccordo di aspirazione
6. Supporto per basamento (opzionale)

Consigliamo una verifica della compatibilità chimica tra il prodotto dosato ed i materiali a contatto.

MATERIALI CHE COMPONGONO LA TESTA DELLA POMPA

- **Corpo pompa:** PVDF-T
- **Valvole:** PVDF-T
- **Sfere:** Ceramica
- **Membrana:** PTFE

CARATTERISTICHE TECNICHE

- **Peso:** 1,5 Kg
- **Alimentazione:** 100 ÷ 240 Vac (50-60 Hz)
- **Assorbimento:** 13W @ 100 Vac – 19W @ 240 Vac
- **Fusibile:** 2A 250V T 5x20
- **Grado di protezione:** IP65
- **Ingresso controllo livello:** Contatto secco (on-off)
- **Ingresso impulsi:** Contatto secco (on-off) frequenza massima 80Hz

LEGGERE ATTENTAMENTE PRIMA DI PROCEDERE ALL'INSTALLAZIONE O AD ATTIVITÀ DI MANUTENZIONE SULLA POMPA.

 **ATTENZIONE:** PRIMA DI PROCEDERE ALL'INSTALLAZIONE O ALLA MANUTENZIONE DELLA POMPA, SCOLLEGARE SEMPRE L'ALIMENTAZIONE.

 **ATTENZIONE:** RACCOMANDIAMO L'INSTALLAZIONE DELLA POMPA IN POSIZIONE VERTICALE PER GARANTIRE IL CORRETTO FUNZIONAMENTO.

 **ATTENZIONE:** PRODOTTO DESTINATO ESCLUSIVAMENTE AD USO PROFESSIONALE, DA PERSONALE QUALIFICATO.

 **ATTENZIONE:** LA MANUTENZIONE DELLA POMPA MUST DEVE ESSERE EFFETTUATA SOLO DA PERSONALE QUALIFICATO ED AUTORIZZATO.

- **H₂SO₄ ACIDO SOLFORICO** Prima di dosare prodotti chimici che possono reagire con l'acqua occorre asciugare tutte le parti interne dell'idraulica.
- Temperatura ambiente inferiore a 40°C. Umidità relativa inferiore a 90%. Grado di protezione IP65. Evitare d'installare la pompa direttamente esposta ai raggi del sole.
- Fissare saldamente la pompa per prevenire vibrazioni eccessive.
- La tensione di alimentazione e la pressione sull'impianto devono essere compatibili con quanto riportato sull'etichetta della pompa.

COLLEGAMENTI ELETTRICI

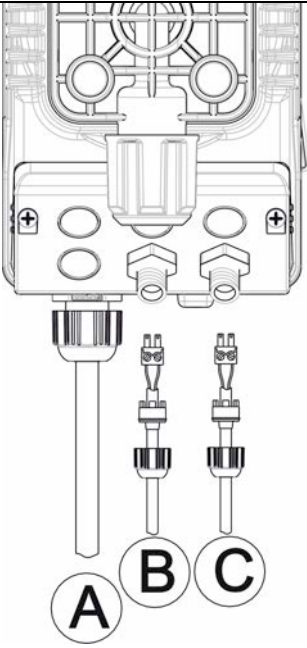
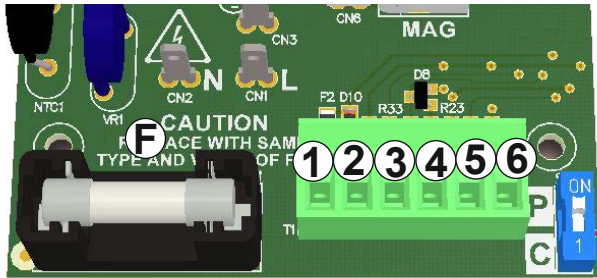
	<p>Ingresso A = Alimentazione 100 ÷ 240 Vac (50-60 Hz)</p> <p>Ingresso B = Impulsi liberi da tensione (contatore lancia-impulsi o sensore hall)</p> <p>Ingresso C = Ingresso sonda controllo livello</p>	<p>La pompa deve essere collegato ad una alimentazione conforme a quella indicata sull'etichetta sul lato della pompa. Il mancato rispetto di queste indicazioni può causare danni alla pompa stessa.</p> <p>Le pompe sono state progettate per assorbire piccole extratensioni. Pertanto, al fine di evitare che la pompa venga danneggiata, è sempre preferibile assicurare che la pompa non abbia una fonte di energia condivisa con gli apparecchi elettrici che generano alte tensioni.</p> <p>La connessione con la linea trifase 380V DEVE essere effettuata solo tra fase e neutro. La connessioni NON DEVE essere effettuata tra fase e terra.</p>																		
	<table border="1"> <tr> <td>1</td> <td>Tensione uscita 10 Vcc</td> </tr> <tr> <td>2</td> <td>Segnale</td> </tr> <tr> <td>4</td> <td>GND</td> </tr> <tr> <td>3</td> <td>Non usato</td> </tr> <tr> <td>2</td> <td>Impulsi liberi da tensione (contatore lancia-impulsi; contatto secco: on-off, frequenza massima 80Hz)</td> </tr> <tr> <td>4</td> <td>Ingresso sonda controllo livello (Contatto secco: on-off)</td> </tr> <tr> <td>5</td> <td>Ingresso sonda controllo livello (Contatto secco: on-off)</td> </tr> <tr> <td>6</td> <td>Ingresso sonda controllo livello (Contatto secco: on-off)</td> </tr> <tr> <td>F</td> <td>Fusibile: 2A 250V T 5x20.</td> </tr> </table>	1	Tensione uscita 10 Vcc	2	Segnale	4	GND	3	Non usato	2	Impulsi liberi da tensione (contatore lancia-impulsi; contatto secco: on-off, frequenza massima 80Hz)	4	Ingresso sonda controllo livello (Contatto secco: on-off)	5	Ingresso sonda controllo livello (Contatto secco: on-off)	6	Ingresso sonda controllo livello (Contatto secco: on-off)	F	Fusibile: 2A 250V T 5x20.	<p>Ingresso sensore hall o simile (tensione d'uscita 10 Vcc; corrente massima 5 mA)</p>
1	Tensione uscita 10 Vcc																			
2	Segnale																			
4	GND																			
3	Non usato																			
2	Impulsi liberi da tensione (contatore lancia-impulsi; contatto secco: on-off, frequenza massima 80Hz)																			
4	Ingresso sonda controllo livello (Contatto secco: on-off)																			
5	Ingresso sonda controllo livello (Contatto secco: on-off)																			
6	Ingresso sonda controllo livello (Contatto secco: on-off)																			
F	Fusibile: 2A 250V T 5x20.																			

IMPOSTAZIONI MODALITÀ DOSAGGIO

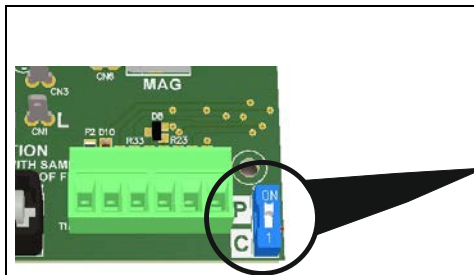

Nella parte relativa alle connessioni elettriche del circuito, è presente uno switch (indicato in figura) che regola le modalità di dosaggio della pompa.

Le due differenti modalità sono:

Costante (switch in posizione C)

La pompa dosa costantemente alla percentuale selezionata con il potenziometro.

Proporzionale (switch in posizione P)

La pompa dosa proporzionalmente al segnale d'ingresso (Contatore lancia-impulsi).

COLLEGAMENTI IDRAULICI

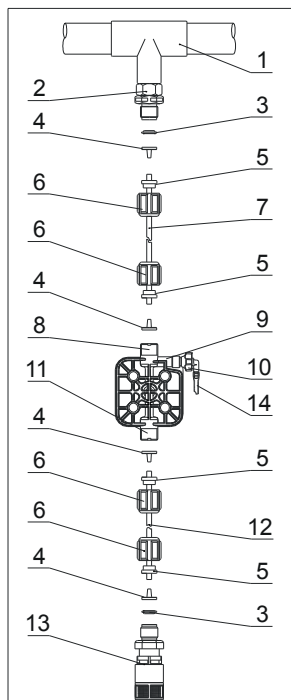

1. Punto d'iniezione
2. Raccordo iniezione
3. Tenuta
4. Porta tubo
5. Pressa tubo
6. Ghiera
7. Tubo mandata (rigido)
8. Valvola di mandata
9. Corpo pompante
10. Valvola di spurgo
11. Valvola di aspirazione
12. Tubo di aspirazione (morbido)
13. Filtro di fondo
14. Raccordo valvola di spurgo

Dime Foratura staffa a muro

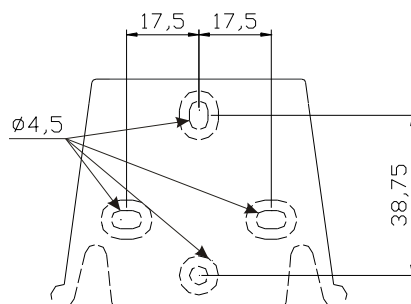

Dopo circa 800 ore di lavoro stringere i bulloni del corpo pompa, applicando una coppia di serraggio di 3 Nm.

Nell'eseguire i collegamenti idraulici occorre osservare le seguenti istruzioni:

- Installare il **FILTRO DI FONDO** a circa 5-10cm dal fondo in modo da evitare che eventuali depositi;
- L'installazione con pompa sottobattente è raccomandata per pompe con portata molto piccola. In particolare quando si dosano prodotti che sviluppino gas (es: ipoclorito di sodio, idrazina, perossido di idrogeno,...).
- Tubi di lunghezza maggiore rispetto a quelli del kit installazione è importante che siano delle stesse dimensioni di quelli forniti con la pompa. Se il **TUBO DI MANDATA** è esposto ai raggi solari si consiglia l'uso di un tubo nero resistenti ai raggi ultravioletti;
- Il **PUNTO DI INIEZIONE** è consigliabile sia posizionato più in alto della pompa o del serbatoio;
- La **VALVOLA DI INIEZIONE**, fornita con la pompa, deve esser sempre installata al termine della linea di mandata del flusso di dosaggio.

AVVIO

Una volta verificate tutte le operazioni descritte in precedenza si è pronti per avviare la pompa.

Adescamento

- Avviare la pompa
- Aprire il raccordo di adescamento ruotando il pomello in senso antiorario ed attendere che fuoriesca del liquido dal tubo ad esso collegato.
- Una volta certi che la pompa è perfettamente piena di liquido si può richiudere il raccordo e la pompa inizia a dosare.

RISOLUZIONE PROBLEMI

Guasto	Possibile causa	Soluzione
La pompa funziona regolarmente ma il dosaggio si è interrotto	Ostruzione delle valvole	Pulire le valvole o sostituirle se non possibile rimuovere le incrostazioni
	Altezza di aspirazione eccessiva	Posizionare la pompa o il serbatoio in modo da ridurre l'altezza d'aspirazione
	Liquido troppo viscoso	Ridurre l'altezza d'aspirazione oppure utilizzare una pompa con portate maggiori
Portata insufficiente	Perdite dalle valvole	Controllare il corretto serraggio delle ghiere
	Liquido troppo viscoso	Utilizzare una pompa con portate maggiori oppure ridurre l'altezza d'aspirazione
	Parziale ostruzione delle valvole	Pulire le valvole o sostituirle se non possibile rimuovere le incrostazioni
Portata della pompa irregolare	Tubo PVC trasparente sulla mandata	Utilizzare il tubo in PE opaco sulla mandata
Rottura della membrana	Contropressione eccessiva	Controllare la pressione dell'impianto. Verificare se la valvola d'iniezione è ostruita. Verificare se ci sono ostruzioni tra le valvole di mandata e il punto d'iniezione.
	Funzionamento senza liquido	Verificare la presenza del filtro (valvola) di fondo. Utilizzare una sonda di livello che blocchi la pompa quando finisce il prodotto chimico nel serbatoio
	Membrana non fissata correttamente	Se la membrana è stata sostituita verificare il corretto serraggio della stessa.
La pompa non si accende	Alimentazione insufficiente	Verificare se i valori di targa della pompa corrispondono a quelli della rete elettrica.

Pannello di controllo – HYDRA BC

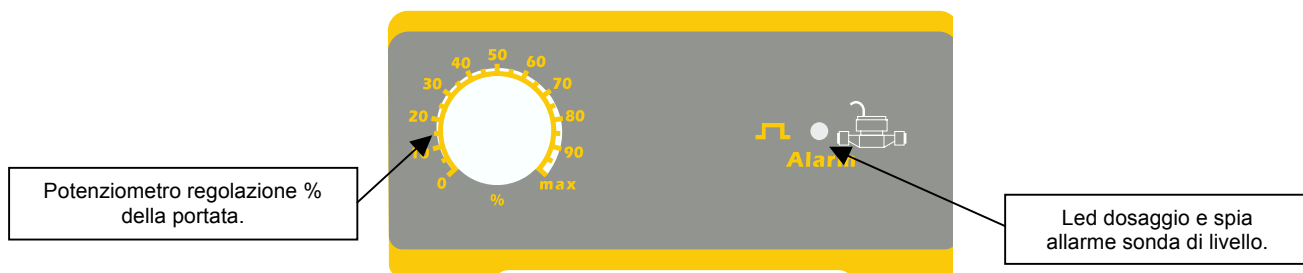

MODALITÀ COSTANTE (switch in posizione C)

La pompa dosa manualmente alla percentuale selezionata con il potenziometro.
 Led verde fisso si spegne ad ogni colpo che la pompa effettua.
 Led verde lampeggiante con il potenziometro a 0.

MODALITÀ PROPORZIONALE 4:1 (switch in posizione P)

La pompa dopo quattro impulsi esterni ricevuti (contatore lancia impulsi) e con il potenziometro al 100% della regolazione, effettua un colpo.
 Il potenziometro permette di aumentare il numero di impulsi esterni ricevuti, dopo i quali la pompa effettuerà un colpo.
 Di seguito degli esempi di funzionamento:

Potenziometro [%]	1 colpo / Impulsi
100	4
50	8
10	40

Led arancione fisso si spegne ad ogni colpo che la pompa effettua.
 Led arancione lampeggiante con il potenziometro a 0.

calibro contatore Q_n		max imp/min fornibili dal contatore $[Q_n \times \text{imp/l}]$				frequenza max della pompa [4 imp contatore = 1 imp pompa]				max ppm dosabili alla frequenza max			
size	m^3/h	imp/l		l/imp		imp/l		l/imp		imp/l		l/imp	
		4	1	100	1000	4	1	100	1000	4	1	100	1000
1/2"	1,5	100	25			25	6			521	130		
3/4"	2,5	167	42			42	10			521	130		
1"	3,5	233	58			58	15			521	130		
1"1/4	5	333	83			83	21			521	130		
1"1/2	10	667	167			160	42			500	130		
2"	15	1.000	250	2,5		160	63	0,63		333	130	1,3	
2"1/2	25			4,2				1,04				1,3	
3"	40			6,7				1,67				1,3	
4"	60			10,0				2,50				1,3	
6"	150				2,5				0,63				0,13

ALLARMI

Visualizzazione	Causa	Interruzione
Accensione led colore rosso fisso.	Allarme fine di livello.	Ripristinare livello liquido.

MANUAL de INSTALAÇÃO E ENTRADA EM FUNCIONAMENTO DA BOMBA DOSEADORA da SÉRIE HYDRA BC

Conteúdo da embalagem:

- A. Tubo opaco para a ligação da saída da bomba até ao ponto de injeção
- B. Tubo transparente para a aspiração, para a ligação da válvula de descarga e a ferragem manual
- C. Raccord de injeção
- D. Kit ligações tubos
- E. Filtro de pé
- F. Suporte para montagem à parede
- G. Âncoras de fixação para suportes à parede
- H. Tampas protecção parafusos
- I. Manual de instruções

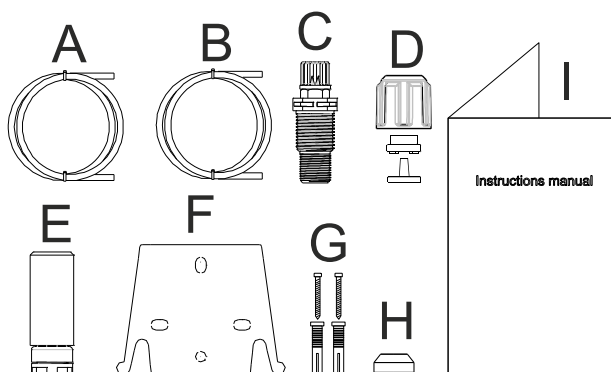

Estes são os dados técnicos e os desempenhos da bomba:

PVDF-T					
Modelo	Pressão	Capacidade	cc /impulso	Conexões (mm)	Impulsos / min
	bar	l/h		Int / Ext	
5	8	5	0,52	4 / 6	160
	10	3			

INTRODUÇÃO

A bomba doseadora é composta por uma parte de comando onde está alojada a eletrónica e o íman e uma parte hidráulica sempre em contacto com o líquido a dosear.

Verifique os dados na etiqueta de características principais da vossa bomba

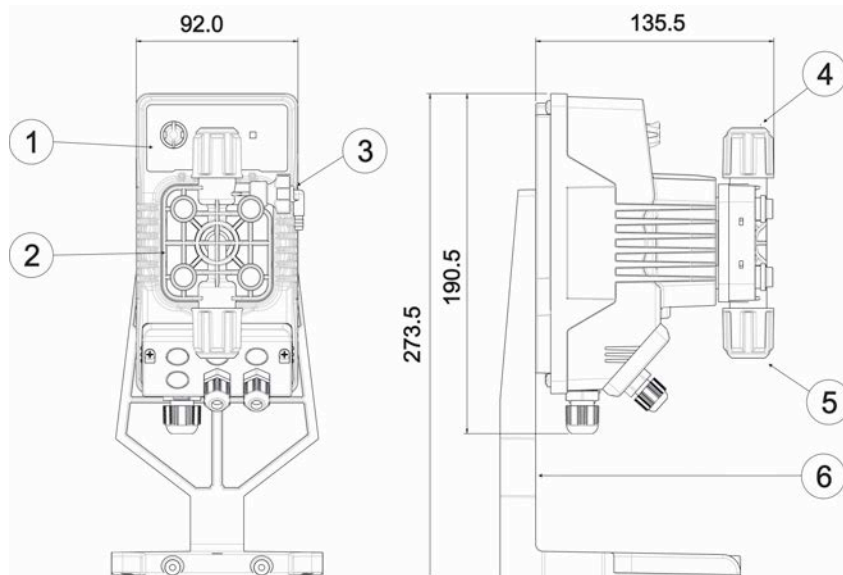

1. Área de regulação
2. Cabeça doseadora
3. Válvula para a ferragem
4. Raccord giratório
5. Raccord de sucção
6. Base de apoio (opcional)

Aconselhamos que se verifique a compatibilidade química entre o produto doseado e os materiais em contacto.

MATERIAIS QUE COMPÕEM A CABEÇA DA BOMBA

- **Corpo bomba:** PVDF-T
- **Válvulas:** PVDF-T
- **Esferas:** Cerâmica
- **Membrana:** PTFE

CARACTERÍSTICAS TÉCNICAS

- **Peso:** 1,5 Kg
- **Alimentação:** 100 ÷ 240 Vac (50-60 Hz)
- **Absorção:** 13W @ 100 Vac – 19W @ 240 Vac
- **Fusível:** 2A 250V T 5x20
- **Gráu de proteção:** IP65
- **Entrada controlo nível:** Contacto seco (on-off)
- **Entrada impulsos:** Contacto seco (on-off) frequência máxima 80Hz

LER ATENTAMENTE ANTES DE PROCEDER À INSTALAÇÃO OU À MANUTENÇÃO DA BOMBA.

 **ATENÇÃO:** ANTES DE PROCEDER À INSTALAÇÃO OU À MANUTENÇÃO DA BOMBA, DESLIGAR A ALIMENTAÇÃO SEMPRE.

 **ATENÇÃO:** RECOMENDAMOS A INSTALAÇÃO DA BOMBA NA POSIÇÃO VERTICAL PARA GARANTIR O SEU CORRETO FUNCIONAMENTO.

 **ATENÇÃO:** PRODUTO DESTINADO EXCLUSIVAMENTE A USO PROFISSIONAL, POR PESSOAL QUALIFICADO.

 **ATENÇÃO:** A MANUTENÇÃO DA BOMBA MUST DEVE SER EFETUADA SÓ POR PESSOAL QUALIFICADO E AUTORIZADO.

- **H₂SO₄ ÁCIDO SULFÚRICO** Antes de dosear produtos químicos que possam reagir com a água é necessário secar todas as partes internas da canalização.
- Temperatura ambiente inferior a 40°C. Humidade relativa inferior a 90%. Gráu de proteção IP65. Evitar instalar a bomba diretamente exposta aos raios do sol.
- Fixar solidamente a bomba para prevenir vibrações excessivas.
- A tensão de alimentação e a pressão na instalação devem ser compatíveis com quanto indicado na etiqueta da bomba.

CABLAGEM

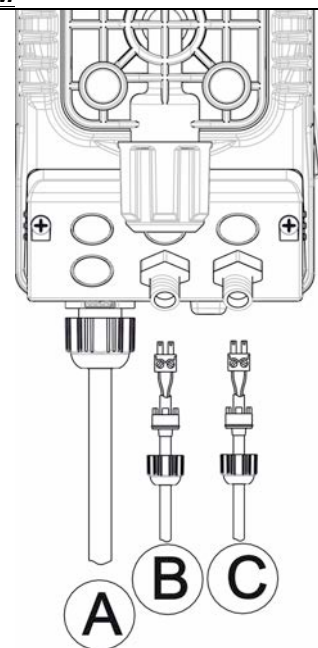
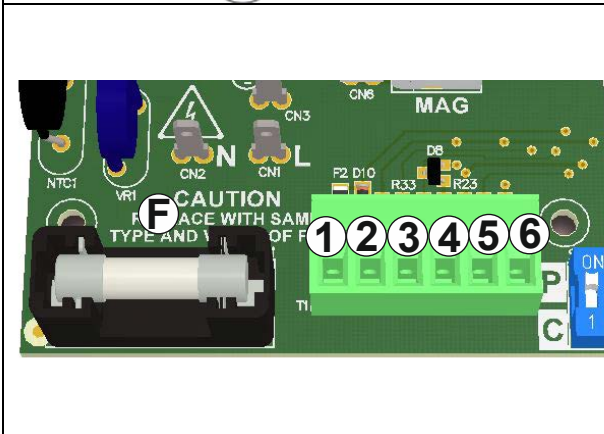
	<p>Entrada A = Alimentação 100 ÷ 240 Vac (50-60 Hz)</p> <p>Entrada B = Batidas sem tensão (contador lança-batida ou sensor hall)</p> <p>Entrada C = Entrada sonda controlo nível</p>	<p>A bomba deve ser ligada a uma alimentação como indicada na etiqueta na parte lateral da bomba. A inexistência destas indicações pode causar danos à própria bomba.</p> <p>As bombas foram projetadas para absorver pequenas voltagens. Assim, para evitar que a bomba seja danificada, é preferível garantir que a bomba não tenha uma fonte de energia partilhada com os aparelhos elétricos que geram altas tensões.</p> <p>A ligação com a linha trifásica 380V DEVE ser efetuada só entre a fase e o neutro. A ligação NÃO DEVE ser efetuada entre a fase e a terra.</p>																	
	<table border="1"> <tr> <td>1</td> <td>Tensão saída 10 Vcc</td> </tr> <tr> <td>2</td> <td>Sinal</td> </tr> <tr> <td>4</td> <td>GND</td> </tr> <tr> <td>3</td> <td>Não usado.</td> </tr> <tr> <td>2</td> <td rowspan="2">Impulsos sem tensão (contador lança-batidas; contacto seco: on-off, frequência máxima 80Hz)</td> </tr> <tr> <td>4</td> </tr> <tr> <td>5</td> <td>Entrada sonda controlo nível</td> </tr> <tr> <td>6</td> <td>(Contacto seco: on-off)</td> </tr> <tr> <td>F</td> <td>Fusível: 2A 250V T 5x20.</td> </tr> </table>	1	Tensão saída 10 Vcc	2	Sinal	4	GND	3	Não usado.	2	Impulsos sem tensão (contador lança-batidas; contacto seco: on-off, frequência máxima 80Hz)	4	5	Entrada sonda controlo nível	6	(Contacto seco: on-off)	F	Fusível: 2A 250V T 5x20.	<p>Entrada sensor hall ou semelhante (tensão de saída 10 Vcc; corrente máxima 5 mA)</p>
1	Tensão saída 10 Vcc																		
2	Sinal																		
4	GND																		
3	Não usado.																		
2	Impulsos sem tensão (contador lança-batidas; contacto seco: on-off, frequência máxima 80Hz)																		
4																			
5	Entrada sonda controlo nível																		
6	(Contacto seco: on-off)																		
F	Fusível: 2A 250V T 5x20.																		

CONFIGURAÇÕES MODALIDADE DOSAGEM

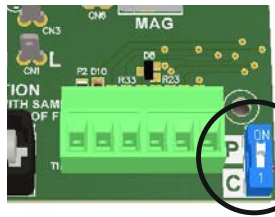

Na parte relativa às ligações elétricas do circuito, há um interruptor (indicado na figura) que regula as modalidades de dosagem da bomba.

As duas diferentes modalidades são:

Constante (interruptor na posição C)

A bomba doseia constantemente à percentagem selecionada com o potenciômetro.

Proporcional (interruptor na posição P)

A bomba doseia proporcionalmente com o sinal de entrada (Contador lança-batidas).

LIGAÇÕES HIDRÁULICAS

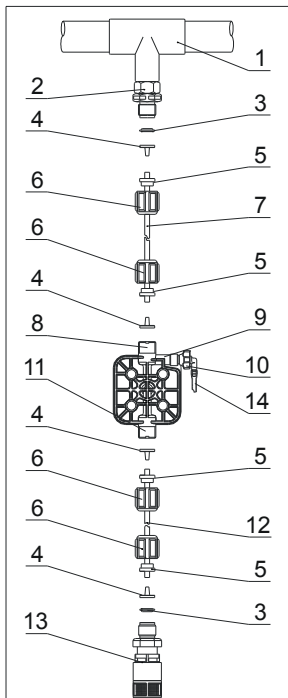

1. Ponto de injeção
2. Raccord de injeção
3. Isolador
4. Suporte de tubulação
5. Braçadeira de tubulação
6. Porca de olhal
7. Mangueira de distribuição (rígido)
8. Válvula de saída
9. Cabeça da bomba
10. Válvula de descarga
11. Válvula de sucção
12. Tubo de aspiração (maleável)
13. Filtro de pé
14. Raccord válvula de descarga

Dimensão Perfuração do suporte de parede

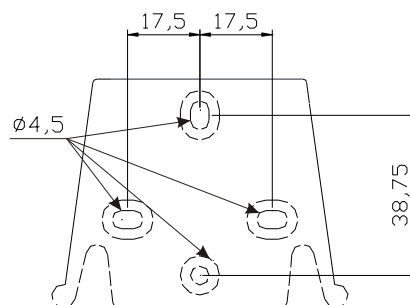

Após cerca de 800 horas de trabalho, aperte os parafusos da cabeça da bomba, aplicando um torque de aperto de 3 Nm.

Ao fazer as ligações de canalização siga as instruções que se seguem:

- Instalar o **FILTRO DE PÉ** a cerca 5-10cm do pé, de forma a evitar qualquer depósito;
- Recomenda-se a instalação com bomba de cabeça para bombas com capacidade muito pequena. Em especial, quando se doseiam produtos que desenvolvam gás (ex: hipoclorito de sódio, hidrazina, peróxido de hidrogénio,...).
- Se necessitar de usar mangueiras maiores, é importante usar mangueiras do mesmo tamanho, como as fornecidas com a bomba. Se a **MANGUEIRA DE DISTRIBUIÇÃO** for exposta aos raios solares aconselha-se o uso de uma mangueira preta, resistente aos raios ultra-violeta;
- É aconselhável que o **PONTO DE INJEÇÃO** seja posicionado acima da bomba ou do tanque;
- A **VÁLVULA DE INJEÇÃO**, fornecida com a bomba, deve ser instalada sempre no final da linha giratória do fluxo de dosagem.

ARRANQUE

Quando todas as operações acima mencionadas tiverem sido realizadas, a bomba está pronta para ser ligada.

Ferragem

- Iniciar a bomba
- Abrir o raccord de ferragem rodando a maçaneta em sentido anti-horário e esperar que saia líquido da mangueira a que está ligado.
- Quando tiver a certeza que a bomba está completamente cheia de líquido, o raccord pode ser fechado de novo e a bomba começa a dosar.

RESOLUÇÃO DE PROBLEMAS

Avaria	Causa possível	Solução
A bomba funciona regularmente, mas a dosagem foi interrompida	Obstrução das válvulas	Limpar as válvulas ou substituí-las se não for possível remover as incrustações
	Altura de sucção excessiva	Posicionar a bomba ou o tanque de forma a reduzir a altura de sucção
	Líquido muito viscoso	Diminuir a altura de sucção, ou utilizar uma bomba com maior capacidade
Capacidade insuficiente	Perdas das válvulas	Verificar se as porcas de olhal são corretamente apertadas
	Líquido muito viscoso	Utilizar uma bomba com maior capacidade ou diminuir a altura de sucção
	Obstrução parcial das válvulas	Limpar as válvulas ou substituí-las se não for possível remover as incrustações
Capacidade irregular da bomba	Tubo PVC transparente na distribuição	Utilizar o tubo em PE opaco na distribuição.
Rotura da membrana	Contrapressão excessiva	Verificar a pressão da instalação. Verificar se a válvula de injeção está obstruída. Verificar se há obstruções entre as válvulas de saída e o ponto de injeção.
	Funcionamento sem líquido	Verificar a presença do filtro (válvula) de pé. Utilizar uma sonda de nível que bloqueie a bomba quando o produto químico no tanque acaba
	Membrana não está fixa corretamente	Se a membrana foi substituída, verificar se a mesma está bem apertada.
A bomba não se liga	Alimentação insuficiente	Verificar se os valores na etiqueta da bomba correspondem aos da rede elétrica.

Painel de controlo – HYDRA BC

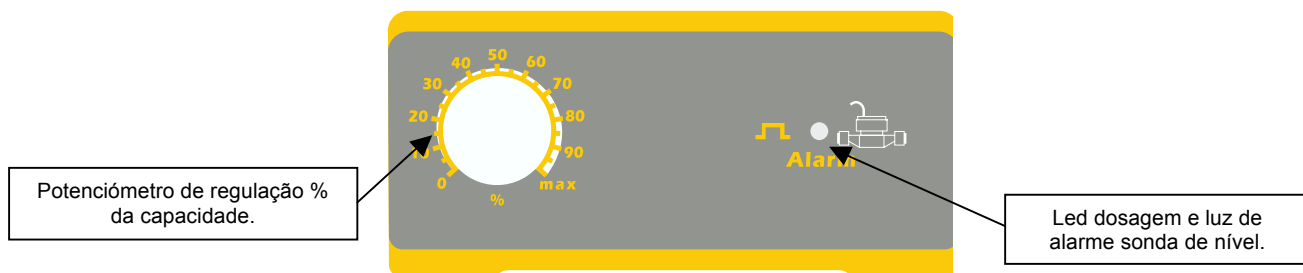

MODALIDADE CONSTANTE (interruptor na posição C)

A bomba doseia manualmente à percentagem seleccionada com o potenciómetro.
 Led verde fixa apaga-se a cada impulso que a bomba efetua.
 Led verde lampejante com o potenciómetro a 0.

MODALIDADE PROPORCIONAL 4:1 (interruptor na posição P)

A bomba depois de receber quatro batidas externas (contador lança batidas) e com o potenciómetro a 100% da regulação, efetua um impulso.
 O potenciómetro permite aumentar o número de batidas externas recebidas, após os quais, a bomba irá efetuar um impulso.
 Seguem-se exemplos de funcionamento:

Potenciómetro [%]	1 impulso / Batidas
100	4
50	8
10	40

Led cor-de-laranja fixo apaga-se a cada golpe que a bomba efetua.
 Led cor de laranja lampejante com o potenciómetro a 0.

calibre contador Q_n		max imp/min fornecíveis pelo contador [$Q_n \times \text{imp/l}$]				frequência max da bomba [4 imp contador = 1 imp bomba]				max ppm doseável à frequência max			
taman	m^3/h	imp/l		l/imp		imp/l		l/imp		imp/l		l/imp	
		4	1	100	1000	4	1	100	1000	4	1	100	1000
1/2"	1,5	100	25			25	6			521	130		
3/4"	2,5	167	42			42	10			521	130		
1"	3,5	233	58			58	15			521	130		
1"1/4	5	333	83			83	21			521	130		
1"1/2	10	667	167			160	42			500	130		
2"	15	1.000	250	2,5		160	63	0,63		333	130	1,3	
2"1/2	25			4,2				1,04				1,3	
3"	40			6,7				1,67				1,3	
4"	60			10,0				2,50				1,3	
6"	150				2,5				0,63				0,13

ALARMES

Visualização	Causa	Interrupção
Ignição led vermelho fixo.	Alarme fim de nível.	Restaurar nível líquido.

HYDRA BC SERİSİ DOZAJ POMPASI İÇİN KURULUM VE ÇALIŞTIRMA KILAVUZU

Ambalajın içindekiler:

- Pompanın çıkışı ile enjeksiyon noktasını bağlamak için opak boru
- Emme, boşaltım valfinin bağlantısı ve manüel pompalama için şeffaf boru
- Enjeksiyon bağlantısı
- Boru bağlantısı kiti
- Taban filtresi
- Duvara montaj levhası
- Duvar levhasının sabitlenmesi için bağlantı parçaları
- Vida koruma kapakları
- Kullanım kılavuzu

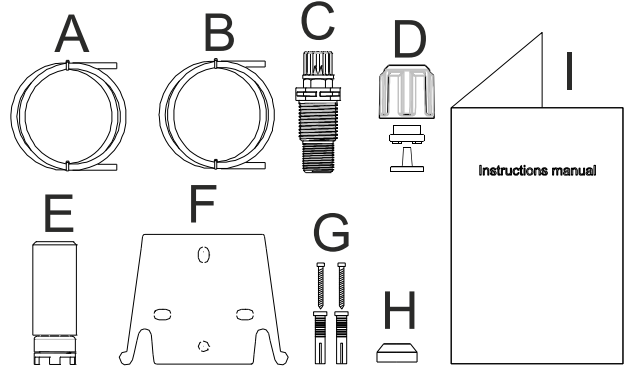

Aşağıda pompanın teknik ve performans verileri sunulmaktadır:

Model	PVDF-T			Bağlantılar (mm)	Vuruş / dak
	Basınç	Kapasite	cc/vuruş		
	bar	l/s		İç / Dış	
5	8	5	0,52	4 / 6	160
	10	3	0,31		

GİRİŞ

Dozaj pompası elektronik kısımlar ve mıknatısın bulunduğu bir kumanda bölümü ile dozajı yapılan sıvıyla sürekli temas halinde olan hidrolik bölümden oluşmaktadır.

Pompanızın ana özelliklerini veri plakasından kontrol ediniz

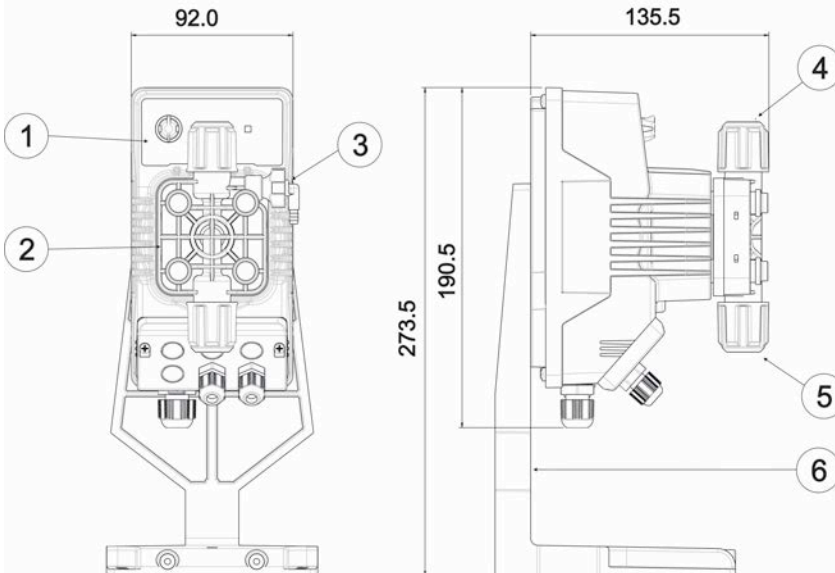

- Ayar bölümü
- Dozaj kafası
- Pompalama valfi
- Çıkış bağlantısı
- Emme bağlantısı
- Taban desteği (opsiyonel)

Dozajı yapılan ürünle temas ettiği malzemeler arasında kimyasal uyumluluk testi yapılması tavsiye edilir.

POMPANIN KAFASINDA KULLANILAN MALZEMELER

- Pompanın gövdesi:** PVDF-T
- Valfler:** PVDF-T
- Bilyeler:** Seramik
- Membran:** PTFE

TEKNİK ÖZELLİKLER

- **Ağırlık:** 1,5 Kg
- **Besleme:** 100 ÷ 240 Vac (50-60 Hz)
- **Emiş:** 13W @ 100 Vac – 19W @ 240 Vac
- **Sigorta:** 2A 250V T 5x20
- **Koruma sınıfı:** IP65
- **Seviye kontrolü girişi:** Kuru kontak (on-off)
- **Darbe girişi:** Kuru kontak (on-off) maksimum frekans 80 Hz

KURULUMA GEÇMEDEN VEYA POMPAYA BAKIM İŞLEMİ YAPMADAN ÖNCE DİKKATLE OKUYUNUZ



DİKKAT: POMPANIN KURULUMUNU VEYA BAKIMINI YAPMADAN ÖNCE HER ZAMAN BESLEMİYİ KESİNİZ.



DİKKAT: DAHA DOĞRU VE DÜZGÜN BİR İŞLEYİŞ İÇİN POMPANIN DIKEY OLARAK MONTE EDILMESINI ÖNERİYORUZ.



DİKKAT: BU ÜRÜN SADECE EHLİYETLİ PERSONEL TARAFINDAN PROFESYONEL AMAÇLARLA KULLANILMAK ÜZERE TASARLANMIŞTIR



DİKKAT: POMPANIN BAKIM İŞLEMLERİ SADECE EHLİYETLİ VE YETKİLİ PERSONEL TARAFINDAN YAPILMALIDIR.

- **H₂SO₄ SÜLFÜRİK ASİT** Suyla reaksiyona girebilecek kimyasal ürünlerin dozajlamasını yapmadan önce hidrolik bölümün tüm iç kısımlarının kurulanması gerekir.
- Ortam ısısı 40°C'nin altında olmalıdır. Nispi nem %90'ın altında olmalıdır. Koruma sınıfı IP 65. Pompanın kurulumunu yaparken güneş ışınlarına doğrudan maruz kalmamasına dikkat ediniz.
- Aşırı vibrasyonu önlemek için pompayı sağlam bir şekilde sabitleyiniz.
- Besleme gerilimi ve basınç pompanın etiketinde belirtilen değerlerde olmalıdır.

ELEKTRİK BAĞLANTILARI

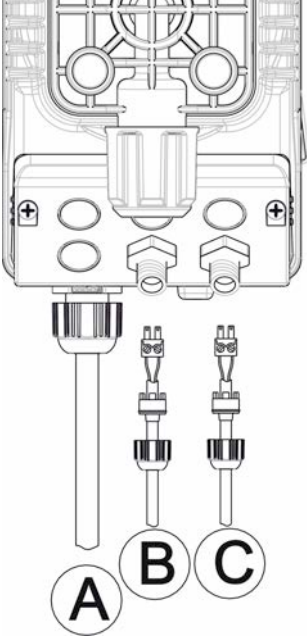
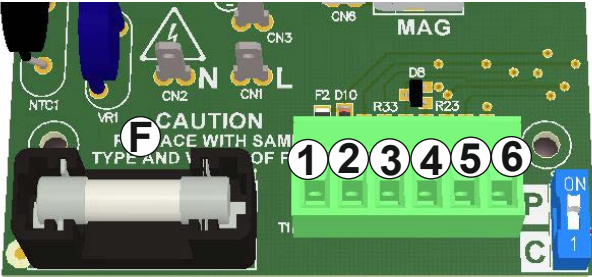
	<p>A girişi = Besleme 100 ÷ 240 Vac (50-60 Hz)</p> <p>B girişi = gerilimsiz darbeler (darbeli sayaç veya hall sensörü)</p> <p>C girişi = Seviye kontrol sondası girişi</p>	<p>Pompa, yan tarafında bulunan etikette belirtilen değerlere uygun bir besleme hattına bağlanmalıdır. Bu talimatlara uyulmaması pompaya zarar gelmesine neden olabilir.</p> <p>Pompalar küçük yüksek gerilimleri tolere edebilecek şekilde tasarlanmışlardır. Dolayısıyla, pompanın zarar görmesini engellemek için her zaman pompanın enerji kaynağının yüksek gerilim yaratan elektrikli aletlere de besleme tedarik eden bir kaynak olmamasına dikkat ediniz.</p> <p>380V trifaze hatlı bağlantı sadece faz-nötr arasında UYGULANMALIDIR. Bağlantı faz-toprak arasında UYGULANMAMALIDIR.</p>	
	1	Çıkış voltajı 10 Vcc	Hall sensörü veya benzerinin girişi (çıkış voltajı 10Vcc; maksimum akım 5 mA)
	2	Sinyal	
	4	GND	
	3	Kullanılmıyor	
	2	Gerilimsiz darbeler (darbeli sayaç; kuru kontak: on-off, maksimum frekans 80 Hz)	
	4	Seviye kontrolü sondası girişi (Kuru kontak: on-off)	
	5	Seviye kontrolü sondası girişi (Kuru kontak: on-off)	
6	Seviye kontrolü sondası girişi (Kuru kontak: on-off)		
F	Sigorta: 2A 250V T 5x20.		

DOZAJ AYARLARI



Devrenin elektrik bağlantılarıyla ilgili kısmında pompanın dozaj ayarlarını düzenleyen (resimde gösterilen) bir düğme mevcuttur.

Mevcut iki ayar aşağıdaki gibidir:

Sürekli (düğme C konumunda) Pompa potansiyometre ile seçilen yüzdeye göre sürekli dozajlama yapar.

Orantılı (düğme P konumunda) Pompa giriş sinyaline orantılı olarak dozajlama yapar (Darbeli sayaç)

HİDROLİK BAĞLANTILAR

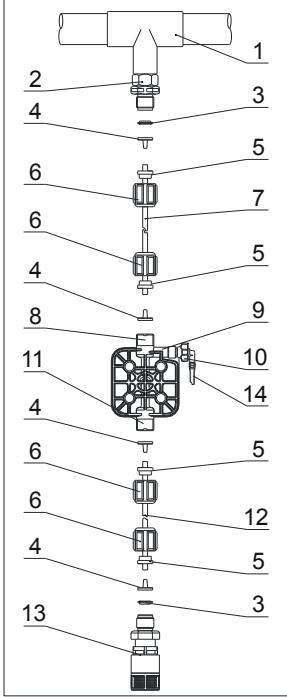

1. Enjeksiyon noktası
2. Enjeksiyon bağlantısı
3. Tutuş
4. Boru kapağı
5. Boru kısılacı
6. Halka somun
7. Çıkış borusu (sert)
8. Çıkış valfi
9. Pompalama gövdesi
10. Boşaltım valfi
11. Emme valfi
12. Emme borusu (yumuşak)
13. Taban filtresi
14. Boşaltım valfi bağlantısı

Duvar montajı için levha delikleri

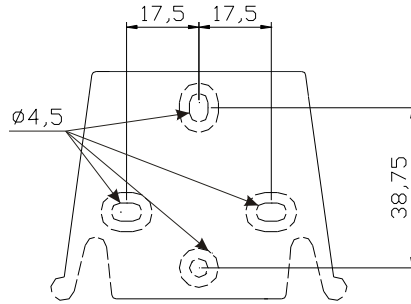

Yaklaşık 800 saatlik çalışmadan sonra pompa gövdesinin civatalarını 3 Nm'lik sıkma torku uygulayarak sıkınız.

Hidrolik bağlantılar yapılırken aşağıdaki talimatlara uyunuz:

- **TABAN FİLTRESİ**'ni tabandan 5-10 santim yukarıya takınız;
- Pompanın minimum sıvı seviyesinin altında olduğu kurulumlar çok düşük kapasiteli pompalar için tavsiye edilir. Özellikle gaz üreten ürünlerin dozajı yapılırken (ör: sodyum hipoklorit, hidrazin, hidrojen peroksit...).
- Kurulum paketindeki borulardan daha uzun borular kullanıldığı zaman ebatlarının pompayla tedarik edilen boruların ebatlarıyla aynı olmasına dikkat ediniz. **ÇIKIŞ BORUSU** doğrudan güneş ışınlarına maruz kaldığı takdirde morötesi ışınlarla dayanıklı siyah boru kullanılması tavsiye edilir;
- **ENJEKSİYON NOKTASI**'nin pompadan veya tanktan yükseğe konumlandırılması tavsiye edilir;
- Pompayla birlikte tedarik edilen **ENJEKSİYON VALFİ** her zaman dozaj akışının çıkış hattının sonuna takılmalıdır.

ÇALIŞTIRMA

Yukarıda tarif edilen tüm kontroller yapıldıktan sonra pompayı çalıştırabilirsiniz.

Pompalama

- Pompayı çalıştırınız
- Topuzu saat yönünün tersine çevirerek pompalama bağlantısını açınız ve bağlı olan borudan sıvının çıkmasını bekleyiniz.
- Pompanın tamamen sıvıyla dolduğundan emin olduktan sonra bağlantıyı kapatabilirsiniz, pompa dozajlama yapmaya başlayacaktır.

PROBLEM ÇÖZME

Arıza	Olası neden	Çözüm
Pompa normal çalışıyor ama dozajlama durdu	Valfler tıkanmış olabilir	Valfleri temizleyiniz veya kirleri temizlemek mümkün olmadığı takdirde değiştiriniz
	Emme yüksekliği aşırı	Pompayı veya tankı emme yüksekliğini azaltacak şekilde konumlandırınız
	Sıvı fazla akışkan	Emme yüksekliğini azaltınız veya daha yüksek kapasiteli bir pompa kullanınız
Taşıma yetersiz	Valflerden kaçak var	Halka somunların iyice sıkıştırılıp sıkıştırılmadığını kontrol ediniz
	Sıvı fazla akışkan	Daha yüksek kapasiteli bir pompa kullanınız veya emme yüksekliğini azaltınız
	Valfler kısmen tıkalı	Valfleri temizleyiniz veya kirleri temizlemek mümkün olmadığı takdirde değiştiriniz
Pompa düzensiz taşıma yapıyor	Şeffaf PVC boru çıkış hattı üzerinde	Çıkış hattında opak PE boruyu kullanınız
Membran yırtıldı	Aşırı karşıbasınç var	Tesisatın basıncını kontrol ediniz. Enjeksiyon valfinin tıkalı olup olmadığını kontrol ediniz. Çıkış valfleri ile enjeksiyon noktası arasında tıkanıklıklar olup olmadığını kontrol ediniz.
	Kuru çalışma	Taban filtresinin (valf) mevcut olup olmadığını kontrol ediniz. Tanktaki kimyasal ürün bittiğinde pompayı bloke eden bir seviye sondası kullanınız
	Membran doğru takılmamış	Membran değiştirildiyse doğru şekilde sıkılıp sıkılmadığını kontrol ediniz.
Pompa çalışmıyor	Besleme yetersiz	Pompanın etiket değerleriyle elektrik şebekesinin değerlerinin uyumlu olup olmadığını kontrol ediniz.

Kumanda paneli - HYDRA BC



SÜREKLİ ÇALIŞMA (düğme C konumunda)

Pompa potansiyometre ile seçilen yüzde değerinde manüel olarak dozajlama yapar. Sabit yanar yeşil led ışığı pompanın her vuruşunda söner. Potansiyometre 0'dayken yeşil led ışığı yanıp sönmeye başlar.

ORANTILI ÇALIŞMA 4:1 (düğme P konumunda)

Pompa dört harici darbeden sonra (darbeli sayaç) ve potansiyometre %100'e ayarlı iken bir vuruş yapar. Potansiyometre ile pompanın ardından bir vuruş yapacağı harici darbelerin sayısı artırılabilir. Aşağıda çalışma örnekleri sunulmaktadır:

Potansiyometre [%]	1 vuruş / Darbe
100	4
50	8
10	40

Sabit yanar turuncu led ışığı pompanın her vuruşunda söner. Potansiyometre 0'dayken turuncu led ışığı yanıp sönmeye başlar.

kalibre sayaç Q_n		mak dar/sayaç min dar				Pompanın mak frekansı [4 sayaç darb = 1 pompa dar]				mak frekansta mak ppm dozajı			
ebat	m^3/h	dar/l		l/dar		dar/l		l/dar		dar/l		l/dar	
		4	1	100	1000	4	1	100	1000	4	1	100	1000
1/2"	1,5	100	25			25	6			521	130		
3/4"	2,5	167	42			42	10			521	130		
1"	3,5	233	58			58	15			521	130		
1"1/4	5	333	83			83	21			521	130		
1"1/2	10	667	167			160	42			500	130		
2"	15	1.000	250	2,5		160	63	0,63		333	130	1,3	
2"1/2	25			4,2				1,04				1,3	
3"	40			6,7				1,67				1,3	
4"	60			10,0				2,50				1,3	
6"	150				2,5				0,63				0,13

ALARMLAR

Görüntüleme	Neden	Kesinti
Sabit kırmızı led ışığı yanar.	Seviye sonu alarmı.	Sıvı seviyesini ayarlayınız.

РУКОВОДСТВО ПО МОНТАЖУ И ПОДКЛЮЧЕНИЮ ДОЗИРУЮЩЕГО НАСОСА СЕРИИ HYDRA BC

Содержимое упаковки:

- A. Матовая труба для подключения выхода насоса к точке нагнетания.
- B. Прозрачная всасывающая труба для подсоединения спускного клапана и для ручного наполнения.
- C. Нагнетательный штуцер
- D. Комплект труб для подключения
- E. Нижний фильтр
- F. Кронштейн для монтажа на стену
- G. Дюбели для крепления кронштейна к стене
- H. Защитные колпачки для винтов
- I. Руководство по эксплуатации

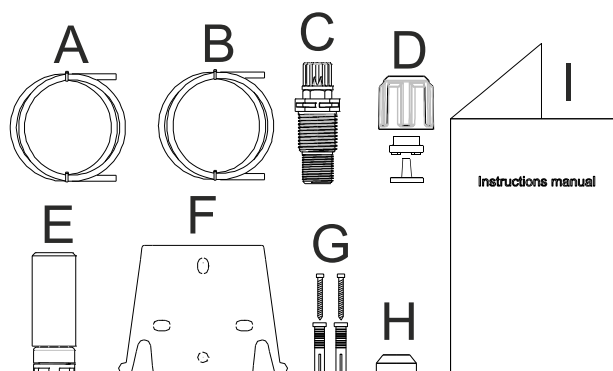

Насос имеет следующие технические данные и характеристики:

Поливинилхлорид (PVDF-T)					
Модель	Давление	Расход	см ³ /уд.	Соединения	Уд./мин.
	бар			л/ч	
5	8	5	0,52	4 / 6	160
	10	3	0,31		

ВВЕДЕНИЕ

Дозирующий насос состоит из блока управления, содержащего электронные детали и магнит, и гидравлической части, находящейся в контакте с дозируемой жидкостью.

Проверить на табличке технических данных основные характеристики вашего насоса.

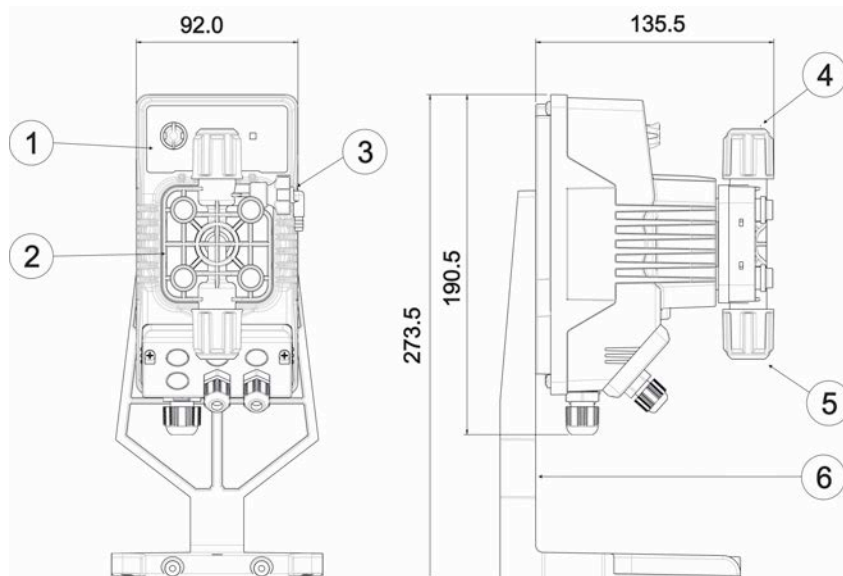

1. Зона регулировки
2. Дозирующая головка
3. Клапан наполнения
4. Нагнетательный штуцер
5. Всасывающий штуцер
6. Опора-основание (факультативно)

Рекомендуем выполнить проверку на химическую совместимость дозируемого продукта с находящимися с ним в контакте материалами насоса.





МАТЕРИАЛЫ, ВХОДЯЩИЕ В СОСТАВ ГОЛОВКИ НАСОСА

- Корпус насоса: Поливинилхлорид (PVDF-T)
- Клапаны: Поливинилхлорид (PVDF-T)
- Шары: Керамика
- Диафрагма: Политетрафторэтилен (PTFE)

ТЕХНИЧЕСКИЕ ХАРАКТЕРИСТИКИ

- **Вес:** 1,5 кг
- **Питание:** 100 ÷ 240 Vac (50-60 Гц)
- **Потребление:** 13Вт @ 100 Vac – 19Вт @ 240 Vac
- **Плавкий предохранитель:** 2А 250В Т 5х20
- **Степень защиты:** IP65
- **Вход контроля уровня:** Сухой контакт (on-off)
- **Вход импульсов:** Сухой контакт (on-off)

ВНИМАТЕЛЬНО ПРОЧИТАТЬ ПЕРЕД ТЕМ, КАК ПРИСТУПАТЬ К УСТАНОВКЕ ИЛИ ТЕХНИЧЕСКОМУ ОБСЛУЖИВАНИЮ НАСОСА

-  **ВНИМАНИЕ:** ВСЕГДА ОТКЛЮЧАТЬ ПИТАНИЕ ПЕРЕД ВЫПОЛНЕНИЕМ УСТАНОВКИ ИЛИ ТЕХНИЧЕСКОГО ОБСЛУЖИВАНИЯ НАСОСА.
-  **ВНИМАНИЕ:** РЕКОМЕНДУЕМ УСТАНОВКУ НАСОСА В ВЕРТИКАЛЬНОМ ПОЛОЖЕНИИ ДЛЯ ОБЕСПЕЧЕНИЯ ПРАВИЛЬНОГО ФУНКЦИОНИРОВАНИЯ.
-  **ВНИМАНИЕ:** ИЗДЕЛИЕ ПРЕДНАЗНАЧЕНО ИСКЛЮЧИТЕЛЬНО ДЛЯ ПРОФЕССИОНАЛЬНОГО ИСПОЛЬЗОВАНИЯ КВАЛИФИЦИРОВАННЫМ ПЕРСОНАЛОМ.
-  **ВНИМАНИЕ:** ТЕХНИЧЕСКОЕ ОБСЛУЖИВАНИЕ НАСОСА ДОЛЖНО ВЫПОЛНЯТЬСЯ ТОЛЬКО УПОЛНОМОЧЕННЫМ И КВАЛИФИЦИРОВАННЫМ ПЕРСОНАЛОМ.

- **H₂SO₄ СЕРНАЯ КИСЛОТА** Перед дозированием химических веществ, вступающих в реакцию с водой, следует высушить все внутренние гидравлические части.
- Температура окружающей среды ниже 40°C. Относительная влажность ниже 90%. Степень защиты IP65. Избегать устанавливать насос в месте, где на него воздействуют прямые солнечные лучи.
- Прочно закрепить насос для предотвращения чрезмерных вибраций.
- Напряжение питания и давление на входе в установку должны быть совместимы с данными, приведенными на табличке насоса.

ЭЛЕКТРИЧЕСКИЕ ПОДКЛЮЧЕНИЯ

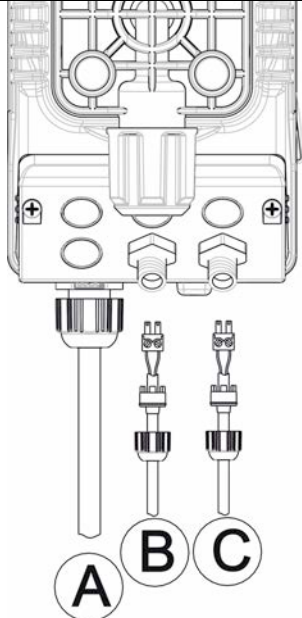
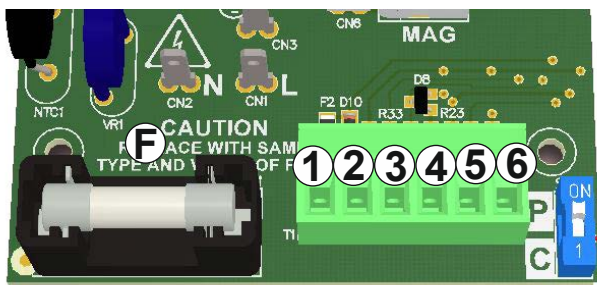
	<p>Вход А = Питание 100 ÷ 240 Vac (50-60 Гц)</p> <p>Вход В = Беспотенциальные импульсы (счетчик генератор импульсов или датчик Холла)</p> <p>Вход С = Вход зонда контроля уровня</p>	<p>Насос должен быть подключен к питанию, соответствующему указанному в табличке на боковой стороне насоса. Несоблюдение этих указаний может привести к повреждению самого насоса.</p> <p>Насосы были разработаны для потребления низкого напряжения. Поэтому, с целью предотвращения повреждения насоса, рекомендуется избегать источников энергии для насоса, разделенных с другими электроприборами, генерирующими высокие напряжения.</p> <p>Подключение трехфазной линии 380В ДОЛЖНО выполняться только через фазу и нейтраль. Подключение НЕ ДОЛЖНО выполняться через фазу и землю.</p>																
	<table border="1"> <tr> <td>1</td> <td>Выходное напряжение 10Vcc</td> </tr> <tr> <td>2</td> <td>Сигнал</td> </tr> <tr> <td>4</td> <td>Заземление</td> </tr> <tr> <td>3</td> <td>Не используется.</td> </tr> <tr> <td>2</td> <td rowspan="2">Беспотенциальные импульсы (счетчик генератор импульсов; сухой контакт on-off, максимальная частота 80 Гц))</td> </tr> <tr> <td>4</td> </tr> <tr> <td>5</td> <td rowspan="2">Вход зонда контроля уровня (Сухой контакт: on-off)</td> </tr> <tr> <td>6</td> </tr> <tr> <td>F</td> <td>Плавкий предохранитель: 2А 250В Т 5х20</td> </tr> </table>	1	Выходное напряжение 10Vcc	2	Сигнал	4	Заземление	3	Не используется.	2	Беспотенциальные импульсы (счетчик генератор импульсов; сухой контакт on-off, максимальная частота 80 Гц))	4	5	Вход зонда контроля уровня (Сухой контакт: on-off)	6	F	Плавкий предохранитель: 2А 250В Т 5х20	<p>Вход датчика Холла или аналогичного (выходное напряжение 10 Vcc; максимальный ток 5 мА)</p>
1	Выходное напряжение 10Vcc																	
2	Сигнал																	
4	Заземление																	
3	Не используется.																	
2	Беспотенциальные импульсы (счетчик генератор импульсов; сухой контакт on-off, максимальная частота 80 Гц))																	
4																		
5	Вход зонда контроля уровня (Сухой контакт: on-off)																	
6																		
F	Плавкий предохранитель: 2А 250В Т 5х20																	

НАСТРОЙКИ РЕЖИМОВ ДОЗИРОВАНИЯ

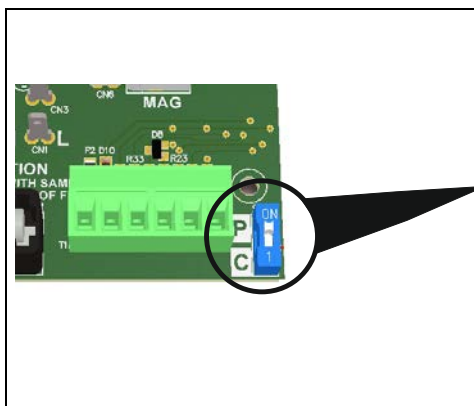

В части, относящейся к электрическим соединениям цепи, находится переключатель (показанный на рисунке), регулирующий режим дозирования насоса.

Существуют два следующих различных режима:

Постоянный (переключатель в положении С)

Насос выполняет постоянное дозирование в соответствии с процентом, выбранным с помощью потенциометра.

Пропорциональный (переключатель в положении Р)

Насос выполняет дозирование пропорционально входному сигналу (счетчик генератор импульсов).

ГИДРАВЛИЧЕСКИЕ ПОДКЛЮЧЕНИЯ

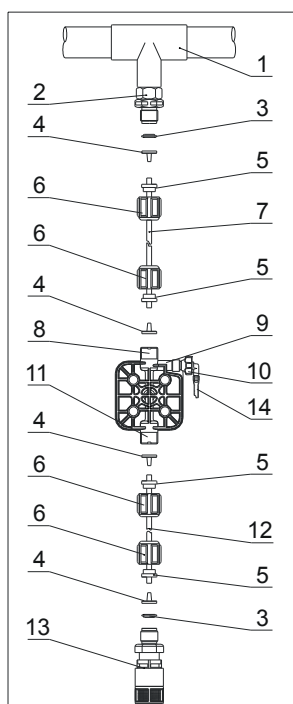

1. Точка нагнетания
2. Нагнетательный штуцер
3. Уплотнение
4. Трубодержатель
5. Муфта для трубы
6. Зажимное кольцо
7. Нагнетательная труба (жесткая)
8. Нагнетательный клапан
9. Корпус насоса
10. Спускной клапан
11. Всасывающий клапан
12. Всасывающая труба (мягкая)
13. Нижний фильтр
14. Штуцер спускного клапана

Шаблон отверстий настенного кронштейна

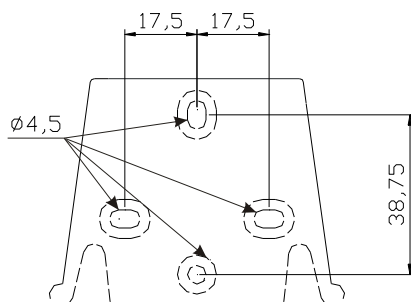

После 800 часов работы затянуть болты корпуса насоса, прилагая момент затяжки **3 Н·м**.

При выполнении гидравлических подключений необходимо следовать следующим инструкциям:

- Установить **НИЖНИЙ ФИЛЬТР** в 5-10 см от дна так, чтобы избежать возможных отложений;
- Насосы с очень малым расходом рекомендуется устанавливать ниже высоты всасывания. Особенно при дозировании продуктов, выделяющих газ (пр.: гипохлорит натрия, гидразин, пероксид водорода и т.д.)
- Трубы с длиной, превышающей длину труб из комплекта установки, должны иметь такие же размеры, как и те, что поставляются с насосом. Если **НАГНЕТАТЕЛЬНАЯ ТРУБА** подвергается воздействию солнечных лучей, рекомендуется использовать трубу черного цвета, устойчивую к воздействию ультрафиолетового излучения;
- **ТОЧКУ НАГНЕТАНИЯ** рекомендуется располагать выше насоса или бака;
- **НАГНЕТАТЕЛЬНЫЙ КЛАПАН**, поставляемый с насосом, должен всегда устанавливаться в конце нагнетательной линии дозируемого потока.

ЗАПУСК

После проверки всех вышеописанных условий насос готов к запуску.

Наполнение

- Включить насос
- Открыть штуцер наполнения, повернув рукоятку против часовой стрелки, и дождаться выхода жидкости из подсоединенной к нему трубы.
- Убедившись, что насос полностью заполнен жидкостью, закрыть штуцер, насос готов к дозированию.

РАЗРЕШЕНИЕ ПРОБЛЕМ

Неисправность	Возможная причина	Решение
Насос работает нормально, но дозирование прекращено	Засорение клапанов	Очистить клапаны или заменить их, если невозможно удалить накипь.
	Чрезмерная высота всасывания	Установить насос или бак таким образом, чтобы уменьшить высоту всасывания
	Слишком вязкая жидкость	Уменьшить высоту всасывания или использовать насос с большим расходом
Недостаточный расход	Утечки из клапанов	Проверить правильность затяжки зажимных колец
	Слишком вязкая жидкость	Использовать насос с большим расходом или уменьшить высоту всасывания
	Частичное засорение клапанов	Очистить клапаны или заменить их, если невозможно удалить накипь.
Расход насоса неравномерный	Прозрачная нагнетательная труба из PVC.	Использовать в качестве нагнетательной матовую трубу из полиэтилена (PE)
Разрушение диафрагмы	Чрезмерное противодавление	Проверить давление установки. Проверить на засорен ли нагнетательный клапан. Проверить нет ли засоров между нагнетательными клапанами и точкой нагнетания.
	Работа в отсутствие жидкости	Проверить наличие нижнего фильтра (клапана). Использовать зонд уровня, блокирующий насос, когда химический продукт в баке заканчивается.
	Диафрагма закреплена неправильно	Если диафрагма была заменена, проверить правильность ее закрепления.
Насос не включается	Недостаточное питание	Проверить соответствие значений таблички насоса и электрической сети.

Панель управления – HYDRA BC

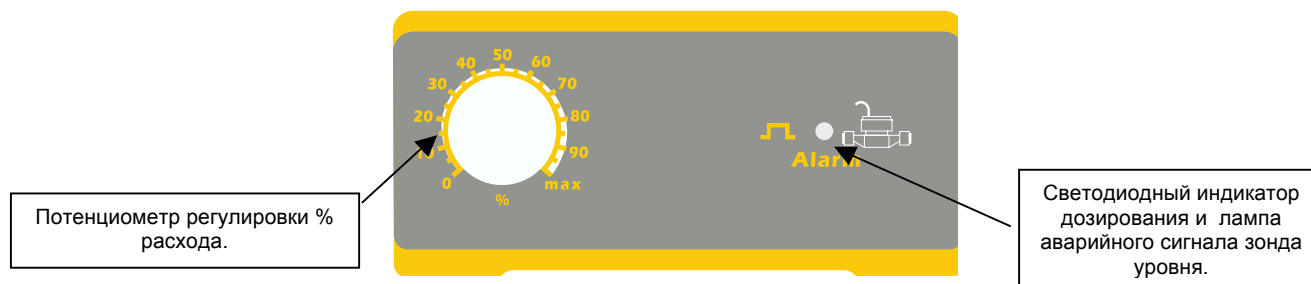

Потенциометр регулировки % расхода.

Светодиодный индикатор дозирования и лампа аварийного сигнала зонда уровня.

ПОСТОЯННЫЙ РЕЖИМ (переключатель в положении С)

Насос выполняет дозирование вручную, согласно проценту, установленному с помощью потенциометра. Зеленый светодиодный индикатор гаснет после каждого хода, выполняемого насосом. При значении потенциометра равном 0, зеленый светодиодный индикатор мигает.

ПРОПОРЦИОНАЛЬНЫЙ РЕЖИМ 4:1 (переключатель в положении Р)

Насос выполняет ход после полученных четырех внешних импульсов (счетчик генератор импульсов) и при потенциометре, установленном на 100% регулировки. Потенциометр позволяет увеличить число внешних полученных импульсов, после которых насос совершит ход.

Ниже приведены примеры работы:

Потенциометр [%]	1 уд./имп.
100	4
50	8
10	40

Оранжевый светодиодный индикатор гаснет после каждого хода, выполняемого насосом. При значении потенциометра равном 0, оранжевый светодиодный индикатор мигает.

калибр счетчика Q_n		Макс. имп./мин. получаемые от счетчика [$Q_n \times$ имп./л]				макс. частота насоса [4 имп. счетчика = 1 имп. насоса]				макс. ppm дозируемые при макс. частоте			
разм.	$м^3/ч$	имп./л		л/имп.		имп./л		л/имп.		имп./л		л/имп.	
		4	1	100	1000	4	1	100	1000	4	1	100	1000
1/2"	1,5	100	25			25	6			521	130		
3/4"	2,5	167	42			42	10			521	130		
1"	3,5	233	58			58	15			521	130		
1"1/4	5	333	83			83	21			521	130		
1"1/2	10	667	167			160	42			500	130		
2"	15	1.000	250	2,5		160	63	0,63		333	130	1,3	
2"1/2	25			4,2				1,04				1,3	
3"	40			6,7				1,67				1,3	
4"	60			10,0				2,50				1,3	
6"	150				2,5			0,63					0,13

АВАРИЙНЫЕ СИГНАЛЫ

Отображение	Причина	Выключение
Включение красного светодиодного индикатора непрерывного света.	Аварийный сигнал минимального уровня.	Восстановить уровень жидкости.